



气动元件产品 选型手册

COUPLING PRODUCT
SELECTION MANUAL



戴维克



了解更多产品 请联系客服

广东戴维克传动科技有限公司

公司简介

COMPANY PROFILE

广东戴维克传动科技有限公司经十几年深耕精密自动化零部件,研发可替代日本、德国、台湾等多国多地区产品,涉及行业:锂电池设备、纺织设备、包装机械、塑料机械、发电设备、木工机械、陶瓷设备.....



品牌经过多年的设计、研发、创新,专业为企业一站式产品选型、技术支持、方案优化,实现高速无忧运转。

戴维克团队“以质量求生存 以服务创品牌”为核心,助力中国制造,推动自动化进步己任,争创中国制造领先企业。

团队介绍

INTRODUCTION TO THE TEAM

戴维克集研发、生产、销售为一体,为更精准服务客户,在珠江三角洲、长江三角洲设立多个分公司,同时设立内销外销、线上线下多渠道推广。

团队高效、务实、精诚协助,满怀信心与期待,在不久的明天与您相遇为您的企业加速助力。

PU接头系列



P1-13

全铜镀镍接头系列



P15-24

黄铜接头系列



P25-29

快速接头系列



P31-35

塑钢接头系列



P36

消声器系列



P37-42

附件系列



P43-51

特点/FEATURES

快插式、快拧式气动管接头用于气动管类系统
管接头具有丰富的型号,可以满足你在气动管类系统中的所胡需要;
即使安装之后,管道的方向任然可以自由改变;
镀镍铜体防腐污染;
所有R和NPT螺纹胶都起密封作用;
所有直螺纹都用标准的O型圈。

THE PUSH-IN FITTINGS ARE USED PNEUMATIC PIPING AND COME IN A WIDE VARIETY OF MODELS TO MEET ALL YOUR NEEDS IN PNEUMATIC PIPING EVEN AFTER INSTALLATION, THE DIRECTION OF THE CAN BE CHANGED FREELY. NICKLE-PLATED METAL BODY ENSURES ANTI-CORROSION AND ANTI-CONTAMINATION. ALL RAND NPT THREADS ARE COATED WITH SEALANT. ALL CYLINDRICAL THREADS ARE EQUIPPED WITH STANDARD O-RING SEALS.

技术参数/SPECIFICATIONS

使用流体 /Fluid	空气, 真空/Air, Vacuum
使用压力范围/Operating Pressure	0-1.0Mpa
负压/Negative Pressure	-100Kpa(10Torr)
耐压/Max Pressure	1.5Mpa
使用温度范围/Operating Temperature	5-60°C
使用软管/Applicable Tube	尼龙及PU/Nylon and Polyurethane

PC 8 - G01 *

①型号MODEL
②气管直径TUBE OUTER DIA.

代号/Code	公制管/Metric Size						英制管/Inch Size					
	4	6	8	10	12	16	5/32	3/16	1/4	5/16	3/8	1/2
气管外径/Tube outer diameter mm	Φ4	Φ6	Φ8	Φ10	Φ12	Φ16	Φ5/32	Φ3/16	Φ1/4	Φ5/16	Φ3/8	Φ1/2

③螺纹型式及尺寸

代号/Code	公制管/Metric Size									
	M5	M6	M8	M10	M12	M12A	M14	M16	M20	
气管外径/Tube outer diameter mm	M5*0.8	M6*1	M8*1	M10*1	M12*1.25	M12*1.5	M14*1.5	M16*1.5	M20*1.5	

55° 锥管螺纹/55° Taper Pipe Thread						
代号/Code	01	02	03	04	06	
螺纹/Thread	R1/8	R1/4	R3/8	R1/2	R3/4	

55° 直管螺纹/55° G-Thread					
代号/Code	G01	G02	G03	G04	G06
螺纹/Thread	G1/8	G1/4	G3/8	G1/2	G3/4

统一细牙螺纹/UNF 美制60° 锥管螺纹/American Standard taper pipe thread(NPT)						
代号/Code	U10	N01	N02	N03	N04	N06
螺纹/Thread	10-32UNF	NPT1/8	NPT1/4	NPT3/8	NPT1/2	NPT3/4

结构图/STRUCTURE CHART

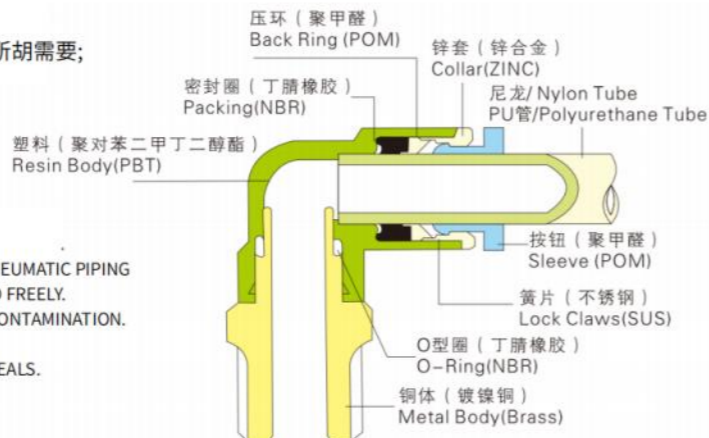

PC/PC-G 型号/MODEL(ΦD-T)							
管 (公制) - 螺纹 (R)		管 (英寸) - 螺纹 (NPT)		管 (公制) - 螺纹 (G)			
Tube(Metric)-Thread(R)		Tube(Inch)-Thread(NPT)		Tube(Metric)-Thread(G)			
04-M5	06-04	12-02	5/32-UNF	1/4-N2	04-G01	10-G01	
04-M6	08-01	12-03	5/32-N1	1/4-N3	04-G02	10-G02	
04-01	08-02	12-04	5/32-N2	1/4-N4	04-G03	10-G03	
04-02	08-03	14-01	5/32-N3	5/16-N1	06-G01	10-G04	
04-03	08-04	14-02	3/16-UNF	5/16-N2	06-G02	12-G02	
06-M5	10-01	14-03	3/16-N1	5/16-N3	06-G03	12-G03	
06-M6	10-02	14-04	3/16-N2	5/16-N4	08-G01	12-G04	
06-01	10-03	16-01	3/16-N3	3/8-N1	08-G02	14-G02	
06-02	10-04	16-02	1/4-UNF	3/8-N2	08-G03	16-G03	
06-03	12-01	16-03	1/4-N1	3/8-N3	08-G04	16-G04	

POC/POC-G 型号/MODEL(ΦD-T)							
管 (公制) - 螺纹 (R)		管 (英寸) - 螺纹 (NPT)		管 (公制) - 螺纹 (G)			
Tube(Metric)-Thread(R)		Tube(Inch)-Thread(NPT)		Tube(Metric)-Thread(G)			
04-M5	06-04	12-02	5/32-UNF	5/16-N2	04-G01	10-G01	
04-M6	08-01	12-03	5/32-N1	5/16-N3	04-G02	10-G02	
04-01	08-02	12-04	5/32-N2	3/8-N1	04-G03	10-G03	
04-02	08-03	14-01	3/16-UNF	3/8-N2	06-G01	10-G04	
04-03	08-04	14-02	3/16-N1	3/8-N3	06-G02	12-G02	
06-M5	10-01	14-03	3/16-N2	3/8-N4	06-G03	12-G03	
06-M6	10-02	14-04	1/4-UNF	1/2-N2	08-G01	12-G04	
06-01	10-03	16-01	1/4-N1	1/2-N3	08-G02	14-G02	
06-02	10-04	16-03	1/4-N2	1/2-N4	08-G03	16-G03	
06-03	12-01	16-04	5/16-UNF		08-G04	16-G04	

PL/PL-G 型号/MODEL(ΦD-T)							
管 (公制) - 螺纹 (R)		管 (英寸) - 螺纹 (NPT)		管 (公制) - 螺纹 (G)			
Tube(Metric)-Thread(R)		Tube(Inch)-Thread(NPT)		Tube(Metric)-Thread(G)			
04-M5	06-04	12-02	5/32-UNF	1/4-N3	04-G01	10-G01	
04-M6	08-01	12-03	5/32-N1	5/16-N1	04-G02	10-G02	
04-01	08-02	12-04	5/32-N2	5/16-N2	04-G03	10-G03	
04-02	08-03	14-01	3/16-UNF	5/16-N3	06-G01	10-G04	
04-03	08-04	14-02	3/16-N1	5/16-N4	06-G02	12-G02	
06-M5	10-01	14-03	3/16-N2	3/8-N1	06-G03	12-G03	
06-M6	10-02	14-04	3/16-N3	3/8-N2	08-G01	12-G04	
06-01	10-03	16-01	1/4-UNF	3/8-N3	08-G02	14-G03	
06-02	10-04	16-02	1/4-N1	3/8-N4	08-G03	16-G03	
06-03	12-01	16-03	1/4-N2	1/2-N2	08-G04	16-G04	

PT/PT-G 型号/MODEL(ΦD-T)							
管 (公制) - 螺纹 (R)		管 (英寸) - 螺纹 (NPT)		管 (公制) - 螺纹 (G)			
Tube(Metric)-Thread(R)		Tube(Inch)-Thread(NPT)		Tube(Metric)-Thread(G)			
04-M5	06-04	12-02	5/32-UNF	1/4-N3	04-G01	10-G01	
04-M6	08-01	12-03	5/32-N1	5/16-N1	04-G02	10-G02	
04-01	08-02	12-04	5/32-N2	5/16-N2	04-G03	10-G03	
04-02	08-03	14-01	3/16-UNF	5/16-N3	06-G01	10-G04	
04-03	08-04	14-02	3/16-N1	5/16-N4	06-G02	12-G02	
06-M5	10-01	14-03	3/16-N2	3/8-N1	06-G03	12-G03	
06-M6	10-02	14-04	3/16-N3	3/8-N2	08-G01	12-G04	
06-01	10-03	16-01	1/4-UNF	3/8-N3	08-G02	14-G01	
06-02	10-04	16-03	1/4-N1	3/8-N4	08-G03	16-G03	
06-03	12-01	16-04	1/4-N2	1/2-N2	08-G04	16-G04	

PST/PST-G 型号/MODEL(ΦD-T)

管(公制)-螺纹(R) Tube(Metric)-Thread(R)		管(英寸)-螺纹(NPT) Tube(Inch)-Thread(NPT)		管(公制)-螺纹(G) Tube(Metric)-ThreadG	
04-M5	06-04	12-02	5/32-UNF	1/4-N3	04-G01
04-M6	08-01	12-03	5/32-N1	5/16-N1	04-G02
04-01	08-02	12-04	5/32-N2	5/16-N2	04-G03
04-02	08-03	14-01	3/16-UNF	5/16-N3	06-G01
04-03	08-04	14-02	3/16-N1	5/16-N4	06-G02
06-M5	10-01	14-03	3/16-N2	3/8-N1	06-G03
06-M6	10-02	14-04	3/16-N3	3/8-N2	08-G01
06-01	10-03	16-01	1/4-UNF	3/8-N3	08-G02
06-02	10-04	16-02	1/4-N1	3/8-N4	08-G03
06-03	12-01	16-03	1/4-N2	1/2-N2	08-G04

PWT/PWT-G 型号/MODEL(ΦD-T)

管(公制)-螺纹(R) Tube(Metric)-Thread(R)		管(英寸)-螺纹(NPT) Tube(Inch)-Thread(NPT)		管(公制)-螺纹(G) Tube(Metric)-ThreadG	
04-M5	06-04	12-02	5/32-UNF	1/4-N3	04-G01
04-M6	08-01	12-03	5/32-N1	5/16-N1	04-G02
04-01	08-02	12-04	5/32-N2	5/16-N2	04-G03
04-02	08-03	14-01	3/16-UNF	5/16-N3	06-G01
04-03	08-04	14-02	3/16-N1	5/16-N4	06-G02
06-M5	10-01	14-03	3/16-N2	3/8-N1	06-G03
06-M6	10-02	14-04	3/16-N3	3/8-N2	08-G01
06-01	10-03	16-01	1/4-UNF	3/8-N3	08-G02
06-02	10-04	16-02	1/4-N1	3/8-N4	08-G03
06-03	12-01	16-03	1/4-N2	1/2-N2	08-G04

PLL/PLL-G 型号/MODEL(ΦD-T)

管(公制)-螺纹(R) Tube(Metric)-Thread(R)		管(英寸)-螺纹(NPT) Tube(Inch)-Thread(NPT)		管(公制)-螺纹(G) Tube(Metric)-ThreadG	
04-M5	06-04	12-02	5/32-UNF	1/4-N3	04-G01
04-M6	08-01	12-03	5/32-N1	5/16-N1	04-G02
04-01	08-02	12-04	5/32-N2	5/16-N2	04-G03
04-02	08-03	14-01	3/16-UNF	5/16-N3	06-G01
04-03	08-04	14-02	3/16-N1	3/8-N2	06-G02
06-M5	10-01	14-03	3/16-N2	3/8-N3	06-G03
06-M6	10-02	14-04	3/16-N3	3/8-N4	08-G01
06-01	10-03	16-01	1/4-UNF	1/2-N2	08-G02
06-02	10-04	16-02	1/4-N1	1/2-N3	08-G03
06-03	12-01	16-03	1/4-N2	1/2-N4	08-G04

PLF/PLF-G 型号/MODEL(ΦD-T)

管(公制)-螺纹(R) Tube(Metric)-Thread(R)		管(英寸)-螺纹(NPT) Tube(Inch)-Thread(NPT)		管(公制)-螺纹(G) Tube(Metric)-ThreadG	
04-M5	08-01	12-04	5/32-UNF	5/16-N1	04-G01
04-M6	08-02	14-01	5/32-N1	5/16-N2	04-G02
04-01	08-03	14-02	5/32-N2	5/16-N3	04-G03
04-02	08-04	14-03	3/16-UNF	3/8-N2	06-G01
06-M5	10-01	14-04	3/16-N1	3/8-N3	06-G02
06-M6	10-02	14-05	3/16-N2	3/8-N4	06-G03
06-01	10-03	16-01	1/4-UNF	1/2-N2	08-G01
06-02	10-04	16-02	1/4-N1	1/2-N3	08-G02
06-03	12-02	16-03	1/4-N2	1/2-N4	08-G03
06-04	12-03	16-04	1/4-N3		08-G04

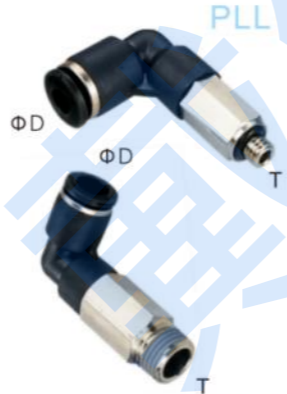

PUC 型号/MODEL(ΦD)

管(公制) Tube(Metric)	管(英寸) Tube(Inch)
04	5/32
06	3/16
08	1/4
10	5/16
12	3/8
14	1/2



PUT 型号/MODEL(ΦD)

管(公制) Tube(Metric)	管(英寸) Tube(Inch)
04	5/32
06	3/16
08	1/4
10	5/16
12	3/8
14	1/2
16	



PG 型号/MODEL(ΦD2-ΦD1)

管(公制) Tube(Metric)	管(英寸) Tube(Inch)
0604	3/16-5/32
0804	1/4-5/32
0806	1/4-3/16
1006	5/16-5/32
1008	5/16-1/4
1208	3/8-1/4
1210	3/8-5/16
1412	1/2-3/8
1612	
1614	



PGT 型号/MODEL(ΦD1-ΦD2)

管(公制) Tube(Metric)	管(英寸) Tube(Inch)
0604	1/4-5/32
0806	5/16-1/4
1006	3/8-1/4
1008	3/8-5/16
1208	1/2-3/8
1210	
1610	
1412	
1612	
1614	



PUL 型号/MODEL(ΦD)

管(公制) Tube(Metric)	管(英寸) Tube(Inch)
04	5/32
06	3/16
08	1/4
10	5/16
12	3/8
14	1/2
16	



PY 型号/MODEL(ΦD)

管(公制) Tube(Metric)	管(英寸) Tube(Inch)
04	5/32
06	3/16
08	1/4
10	5/16
12	3/8
14	1/2



PW 型号/MODEL(ΦD1-ΦD2)

管(公制) Tube(Metric)	管(英寸) Tube(Inch)
0604	3/16-5/32
0804	1/4-5/32
0806	1/4-3/16
1006	5/16-5/32
1008	5/16-1/4
1208	3/8-1/4
1210	3/8-5/16
1412	1/2-3/8
1614	



PZA 型号/MODEL(ΦD)

管(公制) Tube(Metric)	管(英寸) Tube(Inch)
04	5/32
06	3/16
08	1/4
10	5/16
12	3/8
	1/2



PCF

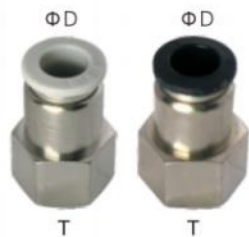

PCF/PCF-G 型号/MODEL(ΦD-T)							
管(公制)-螺纹(R) Tube(Metric)-Thread(R)		管(英寸)-螺纹(NPT) Tube(Inch)-Thread(NPT)		管(公制)-螺纹(G) Tube(Metric)-Thread(G)			
04-M5	08-01	12-03	5/32-N1	PCF5/16-N3	04-G01	08-G04	
04-01	08-02	12-04	5/32-N2	PCF5/16-N4	04-G02	10-G01	
04-02	08-03	14-02	3/16-N1	PCF3/8-N1	04-G03	10-G02	
04-03	08-04	14-03	3/16-N2	PCF3/8-N2	06-G01	10-G03	
06-M5	10-01	14-04	1/4-N1	PCF3/8-N3	06-G02	10-G04	
06-01	10-02	16-02	1/4-N2	PCF3/8-N4	06-G03	12-G02	
06-02	10-03	16-03	1/4-N3	PCF1/2-N2	08-G01	12-G03	
06-03	10-04	16-04	5/16-N1	PCF1/2-N3	08-G02	12-G04	
06-04	12-02		5/16-N2		08-G03		

PMF



PMF/PMF-G 型号/MODEL(ΦD-T)					
管(公制)-螺纹(R) Tube(Metric)-Thread(R)		管(英寸)-螺纹(NPT) Tube(Inch)-Thread(NPT)		管(公制)-螺纹(G) Tube(Metric)-Thread(G)	
04-01	08-04	5/32-N1	3/8-N3	04-G01	10-G02
04-02	10-01	3/16-N1	1/2-N2	04-G02	10-G03
04-03	10-02	3/16-N2	1/2-N3	04-G03	10-G04
06-01	10-03	1/4-N1	1/2-N4	06-G01	12-G02
06-02	10-04	1/4-N2		06-G02	12-G03
06-03	12-02	5/16-N1		06-G03	12-G04
08-01	12-03	5/16-N2		08-G01	
08-02	12-04	5/16-N3		08-G02	
08-03		3/8-N2		08-G03	

PMM



PMM型号/MODEL(ΦD)	
管(公制) Tube(Metric)	管(英寸) Tube(Inch)
04	5/32
06	3/16
08	1/4
10	5/16
12	3/8
	1/2

PLM



PLM型号/MODEL(ΦD)	
管(公制) Tube(Metric)	管(英寸) Tube(Inch)
04	5/32
06	3/16
08	1/4
10	5/16
12	3/8
	1/2

PLJ



PLJ型号/MODEL(ΦD1-ΦD2)	
管(公制) Tube(Metric)	管(英寸) Tube(Inch)
04	5/32
06	3/16
08	1/4
10	5/16
12	3/8
16	1/2
0604	1/4-5/32
0806	5/16-1/4
1008	3/8-1/4
1210	3/8-5/16

PGJ



PGJ型号/MODEL(ΦD1-ΦD2)	
管(公制) Tube(Metric)	管(英寸) Tube(Inch)
0604	1/8-1/4
0804	5/32-1/8
0806	5/32-1/4
1006	1/4-1/8
1008	1/4-5/32
1206	5/16-5/32
1208	5/16-1/4
1210	3/8-1/4
	3/8-5/16
	1/2-1/4
	1/2-5/16
	1/2-3/8

PH/PH-G 型号/MODEL(ΦD-T)					
管(公制)-螺纹(R) Tube(Metric)-Thread(R)		管(英寸)-螺纹(NPT) Tube(Inch)-Thread(NPT)		管(公制)-螺纹(G) Tube(Metric)-Thread(G)	
04-M5	08-02	1/8-UNF	1/4-N3	04-G01	10-G04
04-M6	08-03	5/32-U	5/16-N1	04-G02	12-G03
04-01	08-04	5/32-N1	5/16-N2	06-G01	12-G04
04-02	10-01	5/32-N2	5/16-N3	06-G02	
06-M5	10-02	3/16-UNF	5/16-N4	06-G03	
06-M6	10-03	3/16-N1	3/8-N2	08-G01	
06-01	10-04	3/16-N2	3/8-N3	08-G02	
06-02	12-02	3/16-N3	3/8-N4	08-G03	
06-03	12-03	1/4-UNF	1/2-N3	08-G04	
06-04	12-04	1/4-N1	1/2-N4	10-G02	
08-01		1/4-N2		10-G03	

PH



PHF/PHF-G 型号/MODEL(ΦD-T)					
管(公制)-螺纹(R) Tube(Metric)-Thread(R)		管(英寸)-螺纹(NPT) Tube(Inch)-Thread(NPT)		管(公制)-螺纹(G) Tube(Metric)-Thread(G)	
04-M5	08-02	1/8-UNF	5/16-N1	04-G01	08-G04
04-M6	08-03	5/32-UNF	5/16-N2	04-G02	10-G01
04-01	08-04	5/32-N1	5/16-N3	04-G03	10-G02
04-02	10-01	3/16-UNF	5/16-N4	06-G01	10-G03
06-M5	10-02	3/16-N1	3/8-N2	06-G02	10-G04
06-M6	10-03	3/16-N2	3/8-N3	06-G03	10-G04
06-01	10-04	3/16-N3	3/8-N4	06-G04	12-G03
06-02	12-02	1/4-UNF	1/2-N3	08-G01	12-G04
06-03	12-03	1/4-N1	1/2-N4	08-G02	
06-04	12-04	1/4-N2		08-G03	
08-01		1/4-N3			

PHF



PKD/PKD-G 型号/MODEL(ΦD1-ΦD2)		
管(公制)-螺纹(R) Tube(Metric)-Thread(R)	管(英寸)-螺纹(NPT) Tube(Inch)-Thread(NPT)	管(公制)-螺纹(G) Tube(Metric)-Thread(G)
0604-01	3/16-5/32-N1	0604-G1
0804-01	1/4-5/32-N1	0804-G1
0804-02	5/16-5/32-N2	0804-G2
0806-01	5/16-3/16-N2	0806-G1
0806-02	5/16-1/4-N2	0806-G2
1006-02	3/8-1/4-N3	1006-G2
1006-03	3/8-5/16-N3	1006-G3
1008-02		1008-G2
1008-03		1008-G3

PKD



PKG型号/MODEL(ΦD1-ΦD2)	
管(公制) Tube(Metric)	管(英寸) Tube(Inch)
0604	3/16-5/32
0804	1/4-5-32
0806	5/16-5-32
1006	5/16-3/16
1008	5/16-1/4
	3/8-1/4
	3/8-5/16

PKG



PKJ型号/MODEL(ΦD1-ΦD2)	
管(公制) Tube(Metric)	管(英寸) Tube(Inch)
0604	3/16-5/32
0804	1/4-5-32
0806	5/16-5-32
1006	5/16-3/16
1008	5/16-1/4
	3/8-1/4
	3/8-5/16

PKJ



PYJ



PYJ型号/MODEL(ΦD)	
管(公制) Tube(Metric)	管(英寸) Tube(Inch)
04	5/32
06	3/16
08	1/4
10	5/16
12	3/8
	1/2

PP



PP型号/MODEL(ΦD)	
管(公制) Tube(Metric)	管(英寸) Tube(Inch)
04	5/32
06	3/16
08	1/4
10	5/16
12	3/8
16	1/2

PIJ



PIJ型号/MODEL(ΦD)	
管(公制) Tube(Metric)	管(英寸) Tube(Inch)
04	5/32
06	3/16
08	1/4
10	5/16
12	3/8
16	1/2

PPF



PPF型号/MODEL(ΦD)	
管(公制) Tube(Metric)	管(英寸) Tube(Inch)
04	5/32
06	3/16
08	1/4
10	5/16
12	3/8
16	1/2

PA



PA型号/MODEL(ΦD-T)	
管(公制) Tube(Metric)	管(英寸) Tube(Inch)
04-M5	06-G01
06-01	08-G02
08-02	10-G02
10-02	10-G03
10-03	12-G03
10-03	12-G04
12-04	

PAF



PAF型号/MODEL(ΦD-T)	
管(公制) Tube(Metric)	管(英寸) Tube(Inch)
04-M5	06-G01
06-01	08-G02
08-02	10-G02
10-02	10-G03
10-03	12-G03
12-03	12-G04
12-04	

PWJ



PWJ型号/MODEL(ΦD1-ΦD2)	
管(公制) Tube(Metric)	管(英寸) Tube(Inch)
0604	1/4-5/32
08061	5/16-1/4
1008	3/8-1/4
1210	3/8-5/16

GPL



GPL6-01
GPL6-02
GPL8-02
GPL8-03

特点/FEATURES

快插式、快拧式气动管接头用于气动管类系统
管接头具有丰富的型号,可以满足你在气动管类系统中的所胡需要;
即使安装之后,管道的方向任然可以自由改变;
镀镍铜体防腐污染;
所有R和NPT螺纹胶都起密封作用;
所有直螺纹都用标准的O型圈。

THE PUSH-IN FITTINGS ARE USED PNEUMATIC PIPING AND COME IN A WIDE VARIETY OF MODELS TO MEET ALL YOUR NEEDS IN PNEUMATIC PIPING EVEN AFTER INSTALLATION, THE DIRECTION OF THE CAN BE CHANGED FREELY. NICKLE-PLATED METAL BODY ENSURES ANTI-CORROSION AND ANTI-CONTAMINATION. ALL R AND NPT THREADS ARE COATED WITH SEALANT. ALL CYLINDRICAL THREADS ARE EQUIPPED WITH STANDARD O-RING SEALS.

结构图/STRUCTURE CHART

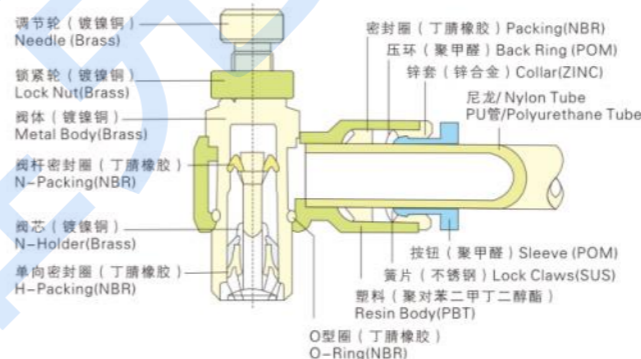

技术参数/SPECIFICATIONS

使用流体 /Fluid	空气(无其他气体和液体) Air(No other gases or liquids)	
使用压力范围 Operating Pressure	0-150PSI	0-9.9Kgf/cm ² (0-990kpa)
负压 Negative Pressure	7.5PSI	0.5Kgf/cm ² (50kpa)
使用温度范围 Operating Temperature	32-140F	0-60℃
使用软管 Applicable Tube	PU及尼龙/ Polyurethane and Nylon	

控制方式/CONTROLWAY

型号/Type	正装/Control Out	反装/Control In
符号 Symbol		
	例: SC06-01	例: SC06-01B

当你定反装的节流阀时,请在型号后面加上B,比如: SC06-01B
When you order Control In type, Please put B at the end of model type. For example, SC06-01B.

SC



SC/SC-G 型号/MODEL(ΦD-T)					
管(公制)-螺纹(R) Tube(Metric)-Thread(R)		管(英寸)-螺纹(NPT) Tube(Inch)-Thread(NPT)		管(公制)-螺纹(G) Tube(Metric)-Thread(G)	
04-M5	08-04	1/8-UNF	1/4-N3	04-G01	10-G02
04-01	10-01	5/32-UNF	5/16-N1	04-G02	10-G03
04-02	10-02	5/32-N1	5/16-N2	06-G01	10-G04
06-M05	10-03	5/32-N2	5/16-N3	06-G02	12-G02
06-01	10-04	3/16-UNF	5/16-N4	06-G03	12-G03
06-02	12-02	3/16-N1	3/8-N2	06-G04	12-G04
06-03	12-03	3/16-N2	3/8-N3	08-G01	
06-04	12-04	3/16-N3	3/8-N4	08-G02	
08-01	4-M6	1/4-UNF	1/2-N3	08-G03	
08-02	6-M6	1/4-N1	1/2-N4	08-G04	
08-03		1/4-N2		10-G01	

SCF



SCF型号/MODEL(ΦD)	
管(公制) Tube(Metric)	管(英寸) Tube(Inch)
04	5/32
06	3/16
08	1/4
10	5/16
12	3/8

DSC



大流量节流阀
DCS8-01
DCS8-02
DCS8-03

作用/APPLICATIONS

手控阀门用来控制空气流向,并且控制气动装置空气压力的开与关;
当设备要进行必要的检查和维修保养时,手控阀可使剩余压力都释放;
有四种类型或供使用。

HAND VALVES ARE USED FOR CONTROLLING THE AIRFLOW AND ARE THE SWITCH OF AIR PRESSURE DEVICES BY SIMPLY TURNING THE HANDLE.
WHEN THE MAINTENANCE OR INSPECTION TO THE EQUIPMENTS IS NECESSARY THE HAND VALVES CAN REMOVE OUT THE REMAINING PRESSURE.
4 TYPES ARE AVAILABLE DEPENDING ON DIFFERENT APPLICATION METHODS

技术参数/SPECIFICATIONS

使用流体 /Fluid	空气(无其他气体和液体) Air(No other gases or liquids)	
使用压力范围 Operating Pressure	0-150PSI	0-9.9Kgf/cm ² (0-990kpa)
负压 Negative Pressure	-29.5in Hg	-750mmHg(-750Torr)
使用温度范围 Operating Temperature	32~140F	0~60°C
使用软管 Applicable Tube	PU及尼龙/ Polyurethane and Nylon	

结构图/STRUCTURE CHART

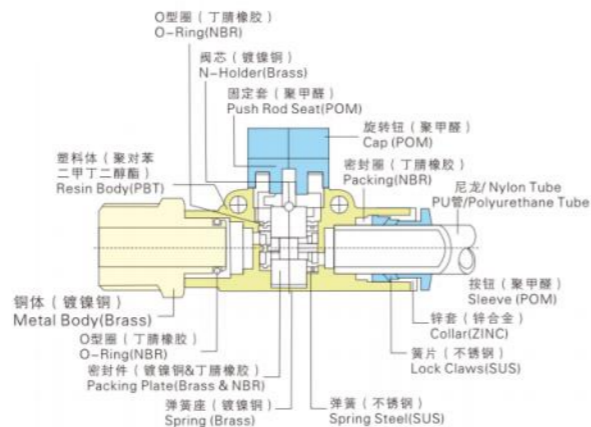

HVSF 型号/MODEL(ΦD-T)					
管(公制)-螺纹(R) Tube(Metric)-Thread(R)	管(英寸)-螺纹(NPT) Tube(Inch)-Thread(NPT)	管(公制)-螺纹(G) Tube(Metric)-Thread(G)			
06-01	10-03	1/4-N1	3/8-N3	06-G01	10-G03
06-02	10-04	1/4-N2	3/8-N4	06-G02	10-G04
06-03	12-02	1/4-N3	1/2-N2	06-G03	12-G02
08-01	12-03	5/16-N1	1/2-N3	08-G01	12-G03
08-02	12-04	5/16-N2	1/2-N4	08-G02	12-G04
08-03		5/16-N3		08-G03	
10-02		3/8-N2		10-G02	

HVSF 型号/MODEL(T-ΦD)					
管(公制)-螺纹(R) Tube(Metric)-Thread(R)	管(英寸)-螺纹(NPT) Tube(Inch)-Thread(NPT)	管(公制)-螺纹(G) Tube(Metric)-Thread(G)			
01-06	02-10	1/4-N1	3/8-N2	G01-06	G02-10
02-06	03-10	1/4-N2	3/8-N3	G02-06	G03-10
03-06	04-10	1/4-N3	3/8-N4	G03-06	G04-10
01-08	02-12	5/16-N1	1/2-N2	G01-08	G02-12
02-08	03-12	5/16-N2	1/2-N3	G02-08	G03-12
03-08	04-12	5/16-N3	1/2-N4	G03-08	G04-12

HVSS 型号/MODEL(T1-T2)					
管(公制)-螺纹(R) Tube(Metric)-Thread(R)	管(英寸)-螺纹(NPT) Tube(Inch)-Thread(NPT)	管(公制)-螺纹(G) Tube(Metric)-Thread(G)			
01-01	N1-N1	G01-G01			
02-01	N2-N1	G02-G01			
02-02	N2-N2	G02-G02			
03-02	N3-N2	G03-G02			
03-03	N3-N3	G03-G03			
04-03	N4-N3	G04-G03			
04-04	N4-N4	G04-G04			

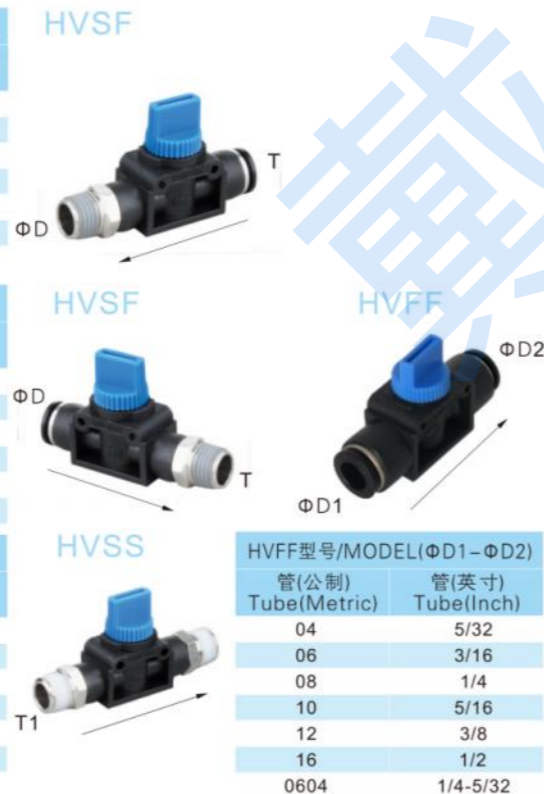

HVFF型号/MODEL(ΦD1-ΦD2)	
管(公制) Tube(Metric)	管(英寸) Tube(Inch)
04	5/32
06	3/16
08	1/4
10	5/16
12	3/8
16	1/2
0604	1/4-5/32

作用/APPLICATIONS

手控阀门用来控制空气流向,并且控制气动装置空气压力的开与关;
当设备要进行必要的检查和维修保养时,手控阀可使剩余压力都释放;
有四种类型或供使用。

HAND VALVES ARE USED FOR CONTROLLING THE AIRFLOW AND ARE THE SWITCH OF AIR PRESSURE DEVICES BY SIMPLY TURNING THE HANDLE.
WHEN THE MAINTENANCE OR INSPECTION TO THE EQUIPMENTS IS NECESSARY THE HAND VALVES CAN REMOVE OUT THE REMAINING PRESSURE.
4 TYPES ARE AVAILABLE DEPENDING ON DIFFERENT APPLICATION METHODS

结构图/STRUCTURE CHART

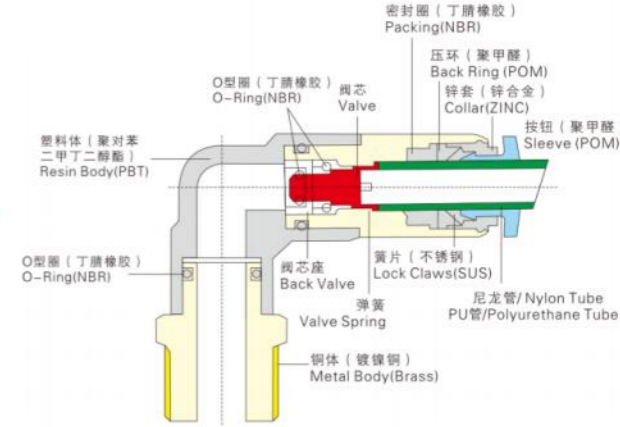

公制-R METRIC-R								
型号 MODEL	ΦD2	ΦP	T	L	A	B	H	
SPC 04-01	4	10	R1/8	26.1	8	15.3	10	
SPC 06-01			R1/8		8		12	
SPC 06-02	6	12	R1/4	23.3	10	17.0	14	
SPC 08-02			R1/4		10		14	
SPC 08-03	8	14	R3/8	33.3	11	18.6	17	
SPC 10-02			R1/4		10		17	
SPC 10-03	10	17	R3/8	35.6	11	20.3	17	
SPC 10-04			R1/2		14		21	
SPC 12-02			R1/4		10		19	
SPC 12-03	11	18.8	R3/8	41.9	11	22.7	19	
SPC 12-04			R1/2		14		21	

公制-R METRIC-R								
型号 MODEL	ΦD2	ΦP	T	L	A	B	H	
SPL 04-M5			M5X0.8P		4.6		10	
SPL 04-M6	4	10	M6X1.0P	34.5	4.1	15.3	10	
SPL 04-01			R1/8		8.0		10	
SPL 06-M6			M5X0.8P		4.6		12	
SPL 06-01	6	12	R1/8	38.9	8.0	17.0	12	
SPL 06-02			R1/4		10.0		14	
SPL 08-01			R1/8		8.0		14	
SPL 08-02	8	14	R1/4	48.6	10.0	18.6	14	
SPL 10-02			R1/4		10.0		17	
SPL 10-03	10	17	R3/8	55.0	11.0	20.3	17	
SPL 10-04			R1/2		14.0		21	
SPL 12-03	12	18.8	R3/8	63.7	11.0	22.7	19	
SPL 12-04			R1/2		14.0		21	

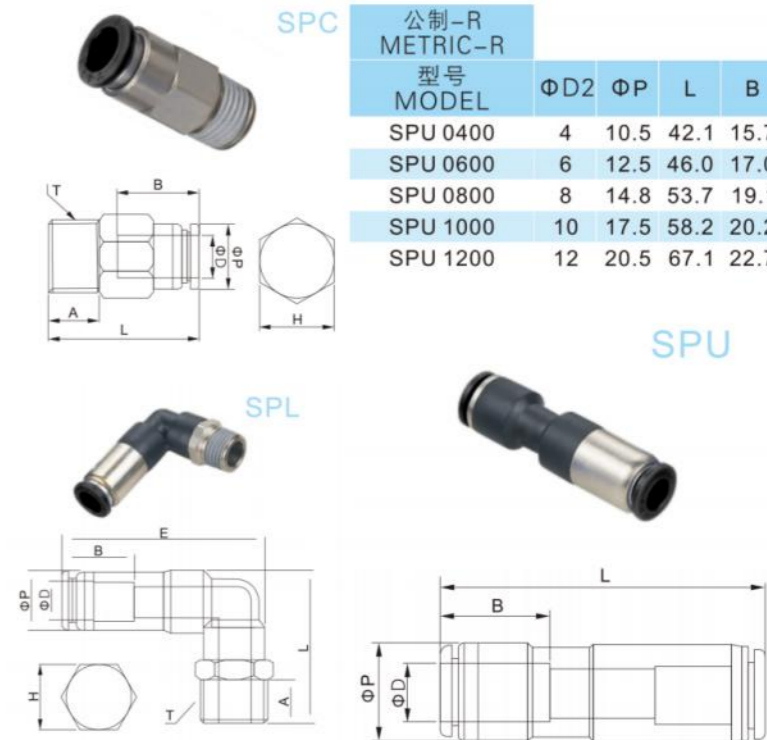

作用/APPLICATIONS

逆止阀允许空气朝一个方向流动
使输出压力保持恒定。
CHECK VALVES PERMIT AIRFLOW IN ONE DIRECTION.
MAINTAIN THE OUTPUT PRESSURE AT CONSTANT LEVEL.

特点/FEATURES

逆止阀允许空气朝一个方向流动,但是阻止了相反的方向。
逆止阀可使工作压力保持在0.1KG/CM2,真空中保持在1.42PSI,并且在低压下进行管道连接。
THE CHECK VALVES PERMIT THE AIRFLOW IN ONE DIRECTION BUT STOPS IN THE REVERSE DIRECTION.
THE CHECK VALVES WORKS AT THE PRESSURE OF 0.1KG/CM2, KEEPS 1.42PSI IN VACUUM AND CONNECTS AT LOW PRESSURE.

技术参数/SPECIFICATIONS

使用流体 /Fluid	空气(无其他气体和液体) Air(No other gases or liquids)	
使用压力范围 Operating Pressure	0-150PSI	0~9.9Kgf/cm ² (0~990kpa)
负压 Negative Pressure	-29.5in Hg	-750mmHg(-750Torr)
使用温度范围 Operating Temperature	32~140°F	0~60°C
使用软管 Applicable Tube	PU及尼龙/ Polyurethane and Nylon	

结构图/STRUCTURE CHART

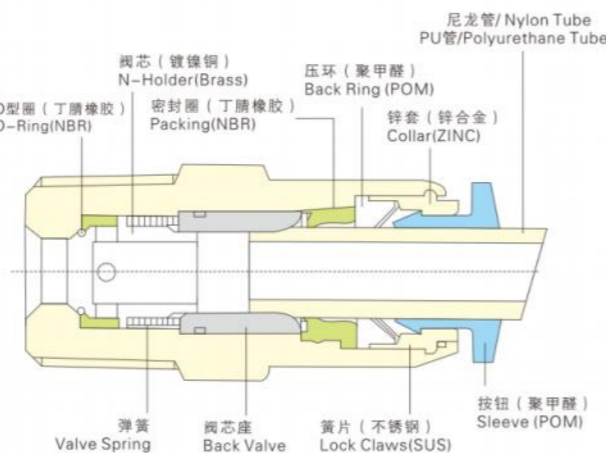

CVPC公制-R METRIC-R							
型号MODEL (ΦD-T)	ΦD	ΦP	T	L	A	B	H
04-M5			M5X08P	31.4	3.6	15.3	10
04-M6	4	10	M6X1.0P	30.4	4.6	15.3	10
04-01			R1/8	27.3	8.0	15.3	10
06-01	6	11.9	R1/8	32.6	8.0	16.3	12
06-02			R1/4	32.6	10.0	16.3	12
08-01	8	14	R1/8	34.9	8.0	18.3	14
08-02			R1/4	37.2	10.0	18.3	14
10-03	10	23	R3/8	56.3	11.0	20.3	22
10-04			R1/2	58.3	14.0	20.3	22
12-03	12	25	R3/8	62.3	12.0	23.3	24
12-04			R1/2	65.3	14.0	23.3	24

CVPF公制-R METRIC-R						
型号MODEL (ΦD-T)	T1	T2	L	A1	A2	H
04-M5	R1/8	R1/8	28.1	8	8	12
04-M6	R1/4	R1/4	34.1	11	11	17
04-01	R3/8	R3/8	53.8	12	12	22
06-01	R1/2	R1/2	61.0	14	14	24

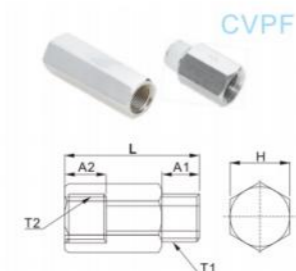
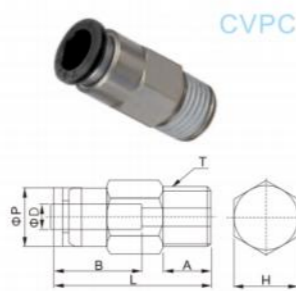

CVPU公制-R METRIC-R				
型号MODEL (ΦD)	ΦD	ΦP	L	B
0400	4	10.5	42.3	15.7
0600	6	12.5	47.5	17.0
0800	8	14.8	56.4	19.1
1000	10	23.0	65.2	20.5
1200	12	25.0	73	23.3



特点/FEATURES

超小型产品(COMPACT),比普通型号体积小40%
外型尺寸小20%,是小型化的ONE-TOUCH FITTING

由于表面有镀铬处理,所以而腐蚀性突出。

SUBMINIATURE PRODUCTS (COMPACT), SMALL VOLUME 40%
THAN COMMON MODEL APPEARANCE SIZE 20%,
THE MINIATURIZATION OF ONE - TOUCH FITTING
DUE TO THE SURFACE OF CHROMIUM PLATING PROCESSING,
SO THE CORROSION RESISTANCE.

结构图/STRUCTURE CHART

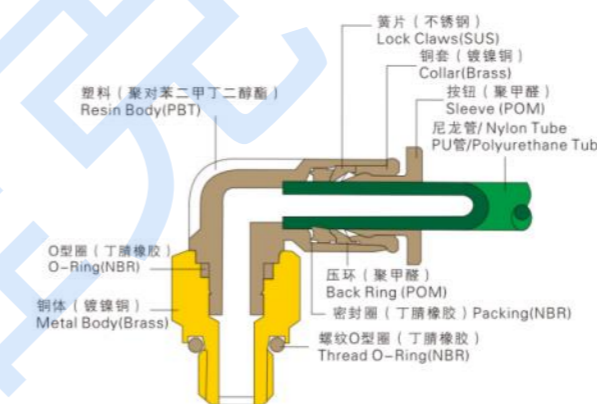

PC-C



型号(ΦD-T)	MODEL(ΦD-T)
管 (公制)-螺纹 (R,公制) Tube(Metric)-Thread(R)	
PC 03-M3C	PC 04-M6C
PC 03-M5C	PC 04-01C
PC 03-M6C	PC-06-M5C
PC 03-01C	PC-06-M6C
PC 04-M3C	PC-06-01C
PC 04-M5C	

PL-C



型号(ΦD-T)	MODEL(ΦD-T)
管 (公制)-螺纹 (R,公制) Tube(Metric)-Thread(R)	
PL 03-M3C	PL 04-01C
PL 03-M5C	PL-06-M5C
PL 03-M6C	PL-06-M6C
PL 04-M3C	PL-06-01C
PL 04-M5C	
PL 04-M6C	

PT-C



型号(ΦD-T)	MODEL(ΦD-T)
管 (公制)-螺纹 (R,公制) Tube(Metric)-Thread(R)	
PT 03-M3C	PT 04-01C
PT 03-M5C	PT 06-M5C
PT 03-M6C	PT 06-M6C
PT 04-M3C	PT 06-01C
PT 04-M5C	
PT 04-M6C	

PST-C



型号(ΦD-T)	MODEL(ΦD-T)
管 (公制)-螺纹 (R,公制) Tube(Metric)-Thread(R)	
PST 03-M3C	PST 04-01C
PST 03-M5C	PST 06-M5C
PST 03-M6C	PST 06-M6C
PST 04-M3C	PST 06-01C
PST 04-M5C	
PST 04-M6C	

公制-锥螺纹/METRIC-BSPT(R)

PC

超小型接头
Compact one Touch fitting

06

规格/Code	尺寸/Size
03	Φ3
04	Φ4
06	Φ6

- 01

规格/Code	尺寸/Size
M3	M3x0.5
M5	M5x0.8
M6	M6x1.0
锥螺纹/R(PT)Thread	
01	R1/8

C

超小型
Compact Nickel

PCF-C



型号(ΦD-T) MODEL(ΦD-T)	
管(公制)-螺纹(R,公制) Tube(Metric)-Thread(R)	
PCF 03-M3C	PCF 04-01C
PCF 03-M5C	PCF 06-M5C
PCF 03-M6C	PCF 06-M6C
PCF 04-M3C	PCF 06-01C
PCF 04-M5C	
PCF 04-M6C	

POC-C



型号(ΦD-T) MODEL(ΦD-T)	
管(公制)-螺纹(R,公制) Tube(Metric)-Thread(R)	
POC 03-M3C	POC 04-01C
POC 03-M5C	POC 06-M5C
POC 03-M6C	POC 06-M6C
POC 04-M3C	POC 06-01C
POC 04-M5C	
POC 04-M6C	

PUC-C



型号 ΦD MODEL ΦD
管(公制) Tube(Metric)
PUC 03C
PUC 04C
PUC 06C

PUL-C



型号 ΦD MODEL ΦD
管(公制) Tube(Metric)
PUL 03C
PUL 04C
PUL 06C

PUT-C



型号 ΦD MODEL ΦD
管(公制) Tube(Metric)
PUT 03C
PUT 04C
PUT 06C

PG-C



型号 ΦD MODEL ΦD
管(公制) Tube(Metric)
PG 04-03C
PG 06-03C
PG 06-04C

PY-C



型号 ΦD MODEL ΦD
管(公制) Tube(Metric)
PY 03C
PY 04C
PY 06C

PW-C



型号 ΦD MODEL ΦD
管(公制) Tube(Metric)
PW 04-03C
PW 06-03C
PW 06-04C

PGJ-C



型号 ΦD MODEL ΦD
管(公制) Tube(Metric)
PGJ 04-03C
PGJ 06-03C
PGJ 06-04C

PMM-C



型号 ΦD MODEL ΦD
管(公制) Tube(Metric)
PMM 03C
PMM 04C
PMM 06C



特点/FEATURES

全铜快插件、快拧式气动管接头用于气动管类系统管接头具有丰富的型号,可以满足您在气动管类系统中的所有需要即使安装之后,管道的方向任然可以自由改变:
 镀镍铜体防腐污染;
 所有R和NPT螺纹胶都起密封作用:
 所有直螺纹都有标准的O型圈。

THE PUSH-IN FITTINGS ARE USED IN PNEUMATIC PIPING AND COME IN A WIDE VARIETY OF MODELS TO MEET ALL YOUR NEEDS IN PNEUMATIC PIPING. EVEN AFTER INSTALLATION, THE DIRECTION OF THE TUBE CAN BE CHANGED FREELY. NICKLE-PLATED METAL BODY ENSURES ANTI-CORROSION AND ANTI-CONTAMINATION. ALL R AND NPT THREADS ARE COATED WITH SEALANT. ALL CYLINDRICAL THREADS ARE EQUIPPED WITH STANDARD O-RING SEALS

技术参数/SPECIFICATIONS

使用温度范围 / Operating Temperature	-20°C~+80°C
使用压力范围 / Operating Pressure	0~1.0Mpa)
使用流体 / Fluid	空气,真空 / Air, Vacuum
使用软管 / Applicable Tube	PU及尼龙/ Polyurethane and Nylon

M PC 8-01

- ① 金属接头/Metal Fitting
- ② 型号/Model
- ③ 插管外径/Tube Outer Diameter
- ④ 螺纹/Thread

结构图/STRUCTURE CHART

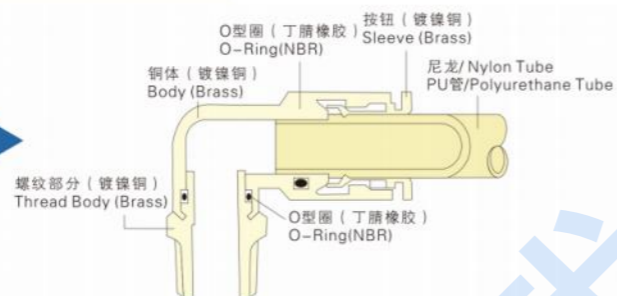

③ 插管及尺寸 / Tube And Size

代号/Code	公制管/Metric Size						英制管/Inch Size					
	4	6	8	10	12	16	5/32	3/16	1/4	5/16	3/8	1/2
气管外径/Tube outer diameter mm	Φ4	Φ6	Φ8	Φ10	Φ12	Φ16	Φ5/32	Φ3/16	Φ1/4	Φ5/16	Φ3/8	Φ1/2

④ 螺纹型式及尺寸 / Thread Type And Size

公制管/Metric Size									
代号/Code	M5	M6	M8	M10	M12	M12A	M14	M16	M20
气管外径/Tube outer diameter mm	M5*0.8	M6*1	M8*1	M10*1	M12*1.25	M12*1.5	M14*1.5	M16*1.5	M20*1.5

55° 锥管螺纹/55° Taper Pipe Thread					
代号/Code	01	02	03	04	06
螺纹/Thread	R1/8	R1/4	R3/8	R1/2	R3/4

55° 直管螺纹/55° G-Thread					
代号/Code	G01	G02	G03	G04	G06
螺纹/Thread	G1/8	G1/4	G3/8	G1/2	G3/4

统一细牙螺纹/UNF 美制60° 锥管螺纹/60° American Standard taper pipe thread(NPT)						
代号/Code	U10	N01	N02	N03	N04	N06
螺纹/Thread	10-32UNF	NPT1/8	NPT1/4	NPT3/8	NPT1/2	NPT3/4

MPBT

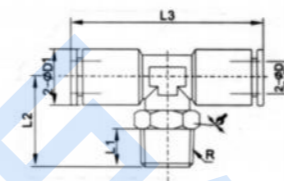

MPBT-G

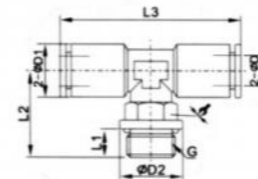

MSC

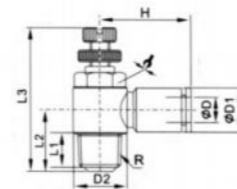

型号/MODEL	ΦD	R	L1	L2	L3	ΦD1	↗
MPBT04-M5	4	M5	3.5	16	35	8.5	10
MPBT04-01		R1/8	8	19.5	35	8.5	10
MPBT04-02		R1/4	10	21.5	35	8.5	14
MPBT06-M5	6	M5	3.5	17	47	11.5	10
MPBT06-01		R1/8	8	20.5	47	11.5	10
MPBT06-02		R1/4	10	22.5	47	11.5	14
MPBT06-03		R3/8	11	24.5	47	11.5	17
MPBT06-04	R1/2	14	27.5	47	11.5	21	
MPBT08-01	8	R1/8	8	21.5	50	13.5	12
MPBT08-02		R1/4	10	23.5	50	13.5	14
MPBT08-03		R3/8	11	25	50	13.5	17
MPBT08-04		R1/2	14	26	50	13.5	21
MPBT10-01	10	R1/8	8	23	58	15.5	14
MPBT10-02		R1/4	10	25	58	15.5	14
MPBT10-03		R3/8	11	26.5	58	15.5	17
MPBT10-04		R1/2	14	29.5	58	15.5	21
MPBT12-02	12	R1/4	10	26.5	60	17.5	17
MPBT12-03		R3/8	11	27.5	60	17.5	17
MPBT12-04		R1/2	14	30.5	60	17.5	21

型号/MODEL	ΦD	G	L1	L2	L3	ΦD1	ΦD2	↗
MPBT04-G01	4	G1/8	5.5	18.5	35	8.5	14	14
MPBT04-G02		G1/4	7.5	22.5	35	8.5	17	10
MPBT06-G01	6	G1/8	5.5	19.5	47	11.5	14	14
MPBT06-G02		G1/4	7.5	23.5	47	11.5	17	10
MPBT06-G03		G3/8	7.5	24.5	47	11.5	20	10
MPBT06-G04		G1/2	10	27	47	11.5	24	10
MPBT08-G01	8	G1/8	5.5	20	50	13.5	14	14
MPBT08-G02		G1/4	7.5	24	50	13.5	17	12
MPBT08-G03		G3/8	7.5	24.5	50	13.5	20	12
MPBT08-G04		G1/2	10	27	50	13.5	24	12
MPBT10-G01	10	G1/8	5.5	22	58	15.5	14	14
MPBT10-G02		G1/4	7.5	26	58	15.5	17	14
MPBT10-G03		G3/8	7.5	26	58	15.5	20	14
MPBT10-G04		G1/2	10	28.5	58	15.5	24	14
MPBT12-G02	12	G1/4	7.5	25.5	60	17.5	17	17
MPBT12-G03		G3/8	7.5	27	60	17.5	20	17
MPBT12-G04		G1/2	10	29.5	60	17.5	24	17

型号/MODEL	ΦD	R	L1	L2	L3(max)	ΦD1	ΦD2	H	↗
MSC04-01	4	R1/8	6.4	15	43	8.5	13	22	12
MSC04-02		R1/4	9	17	48	8.5	16.5	23.5	14
MSC06-01	6	R1/8	6.4	15	43	11.5	13	26.5	12
MSC06-02		R1/4	9	17	48	11.5	16.5	27.5	14
MSC08-01	8	R1/8	6.4	15	43	13.5	13	27.5	12
MSC08-02		R1/4	9	17	48	13.5	16.5	30	14
MSC08-03		R3/8	10.5	20	53	13.5	21	32	19
MSC10-03	10	R3/8	10.5	20	53	15.5	21	35	19

MPC

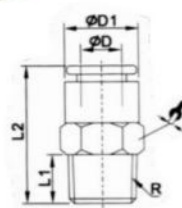

型号/MODEL	ΦD	R	L1	L2	ΦD1	↻
MPC04-M5	4	M5	3.5	20.2	8	8
MPC04-01		R1/8	8	19	8.5	10
MPC04-02		R1/4	10	20.5	8.5	14
MPC06-M5	6	M5	3.5	24.7	11.5	12
MPC06-01		R1/8	8	24.7	11.5	12
MPC06-02		R1/4	10	24.5	11.5	14
MPC06-03		R3/8	11	23	11.5	17
MPC06-04	R1/2	14	26	11.5	21	
MPC08-01	8	R1/8	8	28.7	13.5	14
MPC08-02		R1/4	10	27.7	13.5	14
MPC08-03		R3/8	11	22.7	13.5	17
MPC08-04		R1/2	14	26	13.5	21
MPC10-01	10	R1/8	8	31	15.5	14
MPC10-02		R1/4	10	33	15.5	14
MPC10-03		R3/8	11	27	15.5	17
MPC10-04	R1/2	14	26	15.5	21	
MPC12-02	12	R1/4	10	35	17.5	19
MPC12-03		R3/8	11	31.7	17.5	19
MPC12-04		R1/2	14	26.2	17.5	21

MPC-G

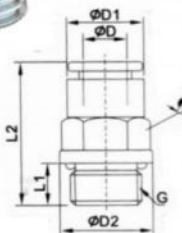

型号/MODEL	ΦD	G	L1	L2	ΦD1	↻
MPC04-M5	4	M5	3.5	20.2	8	8
MPC04-G01		G1/8	5.5	19.4	8.5	10
MPC04-G02		G1/4	7.5	21	8.5	10
MPC06-M5	6	M5	3.5	24.7	11.5	12
MPC06-G01		G1/8	5.5	23.8	11.5	12
MPC06-G02		G1/4	7.5	22.5	11.5	12
MPC06-G03		G3/8	7.5	21.5	11.5	12
MPC06-G04	G1/2	10	23	11.5	12	
MPC08-G01	8	G1/8	5.5	28	13.5	14
MPC08-G02		G1/4	7.5	27	13.5	14
MPC08-G03		G3/8	7.5	22.4	13.5	14
MPC08-G04		G1/2	10	24	13.5	14
MPC10-G01	10	G1/8	5.5	30	15.5	16
MPC10-G02		G1/4	7.5	32	15.5	17
MPC10-G03		G3/8	7.5	28	15.5	17
MPC10-G04		G1/2	10	24.5	15.5	17
MPC12-G02	12	G1/4	7.5	33.7	17.5	19
MPC12-G03		G3/8	7.5	29.7	17.5	20
MPC12-G04		G1/2	10	28	17.5	19

MPUT

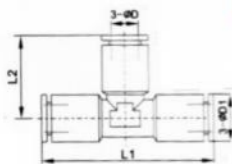

型号/MODEL	ΦD	ΦD1	L1	L2
MPUT04	04	8.5	35	17.5
MPUT06	06	11.5	47	23.5
MPUT08	08	13.5	50	25
MPUT10	10	15.5	58	29
MPUT12	12	17.5	60	30

MSC

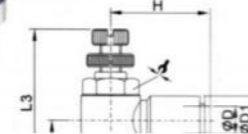

型号/MODEL	ΦD	G	L1	L2	L3(max)	ΦD1	ΦD2	H	↻
MSC04-G01	4	G1/8	5.5	15.5	43	8.5	14	22	12
MSC04-G02		G1/4	6.5	17	48	8.5	17	23.5	14
MSC06-G01	6	G1/8	5.5	15.5	43	11.5	14	26.5	12
MSC06-G02		G1/4	6.5	17	48	11.5	17	27.5	14
MSC08-G01	8	G1/8	5.5	15	43	13.5	14	27.5	12
MSC08-G02		G1/4	6.5	17	48	13.5	17	30	14
MSC08-G03		G3/8	7.5	20	53	13.5	21	32	19
MSC10-G03	10	G3/8	7.5	20	53	15.5	21	35	19

MPL

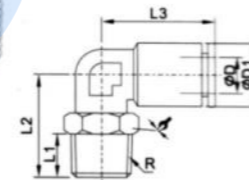
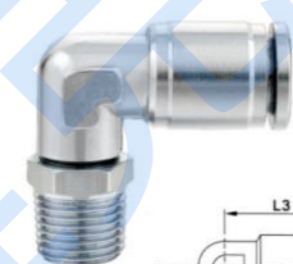

型号/MODEL	ΦD	R	L1	L2	L3	ΦD1	↻
MPL04-M5	4	M5	3.5	16	17.5	8.5	10
MPL04-01		R1/8	8	19.5	17.5	8.5	10
MPL04-02		R1/4	10	21.5	17.5	8.5	14
MPL06-M5	6	M5	3.5	16	23.5	11.5	10
MPL06-01		R1/8	8	19.5	23.5	11.5	10
MPL06-02		R1/4	10	21.5	23.5	11.5	14
MPL06-03		R3/8	11	23.5	23.5	11.5	17
MPL06-04	R1/2	14	26.5	23.5	11.5	21	
MPL08-01	8	R1/8	8	21	25	13.5	12
MPL08-02		R1/4	10	23	25	13.5	14
MPL08-03		R3/8	11	24.5	25	13.5	17
MPL08-04		R1/2	14	25.5	25	13.5	21
MPL10-01	10	R1/8	8	22.5	29	15.5	14
MPL10-02		R1/4	10	24.5	29	15.5	14
MPL10-03		R3/8	11	26	29	15.5	17
MPL10-04		R1/2	14	29	29	15.5	21
MPL12-02	12	R1/4	10	26	30	17.5	17
MPL12-03		R3/8	11	27	30	17.5	17
MPL12-04		R1/2	14	30	30	17.5	21

MPL-G

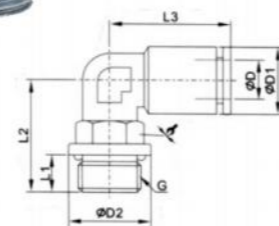

型号/MODEL	ΦD	G	L1	L2	L3	ΦD1	ΦD2	↻
MPL04-G01	4	G1/8	5.5	18.5	17.5	8.5	14	14
MPL04-G02		G1/4	7.5	22.5	17.5	8.5	17	10
MPL06-G01	6	G1/8	5.5	18.5	23.5	11.5	14	14
MPL06-G02		G1/4	7.5	22.5	23.5	11.5	17	10
MPL06-G03		G3/8	7.5	23.5	23.5	11.5	20	10
MPL06-G04		G1/2	10	26	23.5	11.5	24	10
MPL08-G01	8	G1/8	5.5	19.5	25	13.5	14	14
MPL08-G02		G1/4	7.5	23.5	25	13.5	17	12
MPL08-G03		G3/8	7.5	24	25	13.5	20	12
MPL08-G04		G1/2	10	26.5	25	13.5	24	12
MPL10-G01	10	G1/8	5.5	21.5	29	15.5	14	14
MPL10-G02		G1/4	7.5	25.5	29	15.5	17	14
MPL10-G03		G3/8	7.5	25.5	29	15.5	20	14
MPL10-G04		G1/2	10	28	29	15.5	24	14
MPL12-G02	12	G1/4	7.5	25	30	17.5	17	17
MPL12-G03		G3/8	7.5	26.5	30	17.5	20	17
MPL12-G04		G1/2	10	29	30	17.5	24	17

MPUC



型号/MODEL	ΦD	ΦD1	ΦD2	ΦD3	L1
MPUC04	4	4	8.5	8.5	30.3
MPUC06	6	6	11.5	11.5	38.5
MPUC08	8	8	13.5	13.5	40.5
MPUC10	10	10	15.5	15.5	44.5
MPUC12	12	12	17.5	17.5	46.5
MPUC08-06	8	6	13.5	11.5	39.5
MPUC10-08	10	8	15.5	13.5	42.5

MPCF



型号/MODEL	ΦD	Rc	L1	L2	ΦD1	↻
MPCF04-M5	4	M5	5.5	18	8.5	8
MPCF04-01		Rc1/8	8.5	21	8.5	14
MPCF04-02		Rc1/4	11	23.5	8.5	17
MPCF06-M5	6	M5	5.5	22	11.5	12
MPCF06-01		Rc1/8	8.5	25	11.5	14
MPCF06-02		Rc1/4	11	27.5	11.5	17
MPCF06-03	Rc3/8	12	28.5	11.5	21	
MPCF06-04	Rc1/2	14	30.5	11.5	24	
MPCF08-01	8	Rc1/8	8.5	26	13.5	14
MPCF08-02		Rc1/4	11	28.5	13.5	17
MPCF08-03		Rc3/8	12	29.5	13.5	21
MPCF08-04	Rc1/2	14	31.5	13.5	24	
MPCF10-01	10	Rc1/8	8.5	28	15.5	16
MPCF10-02		Rc1/4	11	30.5	15.5	17
MPCF10-03		Rc3/8	12	31.5	15.5	21
MPCF10-04	Rc1/2	14	33.5	15.5	24	
MPCF12-02	12	Rc1/4	11	31.5	17.5	19
MPCF12-03		Rc3/8	12	32.5	17.5	21
MPCF12-04		Rc1/2	14	34.5	17.5	24

MPCF-G



型号/MODEL	ΦD	G	L1	L2	ΦD1	↻
MPCF04-G01	4	G1/8	8.5	21	8.5	14
MPCF04-G02		G1/4	11	23.5	8.5	17
MPCF06-G01	6	G1/8	8.5	25	11.5	14
MPCF06-G02		G1/4	11	27.5	11.5	17
MPCF06-G03		G3/8	12	28.5	11.5	21
MPCF06-G04	G1/2	14	30.5	11.5	24	
MPCF08-G01	8	G1/8	8.5	26	13.5	14
MPCF08-G02		G1/4	11	28.5	13.5	17
MPCF08-G03		G3/8	12	29.5	13.5	21
MPCF08-G04		G1/2	14	31.5	13.5	24
MPCF10-G01	10	G1/8	8.5	28	15.5	16
MPCF10-G02		G1/4	11	30.5	15.5	17
MPCF10-G03		G3/8	12	31.5	15.5	21
MPCF10-G04		G1/2	14	33.5	15.5	24
MPCF12-G02	12	G1/4	11	31.5	17.5	19
MPCF12-G03		G3/8	12	32.5	17.5	21
MPCF12-G04		G1/2	14	34.5	17.5	24

MPUL



型号/MODEL	ΦD	ΦD1	L
MPUL04	4	8.5	17.5
MPUL06	6	11.5	23.5
MPUL08	8	13.5	25
MPUL10	10	15.5	29
MPUL12	12	17.5	30

MPUZ

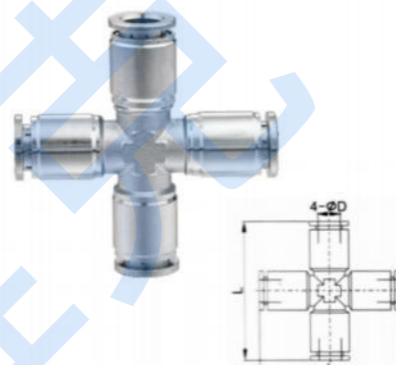

型号/MODEL	ΦD	ΦD1	L
MPUZ04	4	8.5	35
MPUZ06	6	11.5	47
MPUZ08	8	13.5	50
MPUZ10	10	15.5	58
MPUZ12	12	17.5	60

MPM



型号/MODEL	ΦD	ΦD1	L	L1(max)	M	↻
MPM04	4	8.5	30.5	8	M10×1	14
MPM06	6	11.5	38.5	13	M14×1	17
MPM08	8	13.5	40.5	14	M16×1	19
MPM10	10	15.5	44.5	13	M18×1	21
MPM12	12	17.5	46.5	18	M20×1	24

MPGJ



型号/MODEL	ΦD	ΦD1	ΦD2	L1	L2
MPGJ04	4	6	9	21	34.5
MPGJ06	6	8	11.5	22	40
MPGJ08	8	10	13.5	25.5	44.5
MPGJ10	10	12	15.5	26	47

MPST



型号/MODEL	ΦD	R	L1	L2	L3	L4	ΦD1	↻
MPST04-M5	4	M5	3.5	16.5	17.5	34	8.5	10
MPST04-01		R1/8	8	20	17.5	37.5	8.5	10
MPST04-02		R1/4	10	22	17.5	39.5	8.5	14
MPST06-M5	6	M5	3.5	16.5	23.5	41.5	11.5	10
MPST06-01		R1/8	8	20	23.5	45	11.5	10
MPST06-02		R1/4	10	22	23.5	47	11.5	14
MPST06-03	R3/8	11	24	23.5	49	11.5	17	
MPST06-04	R1/2	14	27	23.5	52	11.5	21	
MPST08-01	8	R1/8	8	21.5	25	48.7	13.5	12
MPST08-02		R1/4	10	23.5	25	50.7	13.5	14
MPST08-03		R3/8	11	25	25	52.2	13.5	17
MPST08-04	R1/2	14	26	25	53.2	13.5	21	
MPST10-01	10	R1/8	8	23	29	55	15.5	14
MPST10-02		R1/4	10	25	29	57	15.5	14
MPST10-03		R3/8	11	26.5	29	58.5	15.5	17
MPST10-04	R1/2	14	29.5	29	61.5	15.5	21	
MPST12-02	12	R1/4	10	26.5	30	59.7	17.5	17
MPST12-03		R3/8	11	27.5	30	60.7	17.5	17
MPST12-04		R1/2	14	30.5	30	63.7	17.5	21

MPST-G

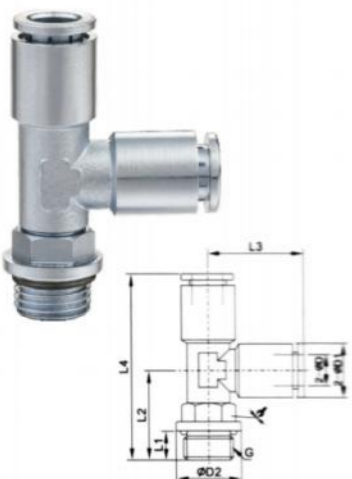

型号/MODEL	ΦD	G	L1	L2	L3	L4	ΦD1	ΦD2	↻
MPST04-G01	4	G1/8	5.5	19	17.5	36.5	8.5	14	14
MPST04-G02		G1/4	7.5	23	17.5	40.5	8.5	17	10
MPST06-G01	6	G1/8	5.5	19	23.5	44	11.5	14	14
MPST06-G02		G1/4	7.5	23	23.5	48	11.5	17	10
MPST06-G03		G3/8	7.5	24	23.5	49	11.5	20	10
MPST06-G04		G1/2	10	26.5	23.5	51.5	11.5	24	10
MPST08-G01	8	G1/8	5.5	20	25	47.2	13.5	14	14
MPST08-G02		G1/4	7.5	24	25	51.2	13.5	17	12
MPST08-G03		G3/8	7.5	24.5	25	51.7	13.5	20	12
MPST08-G04		G1/2	10	27	25	54.2	13.5	24	12
MPST10-G01	10	G1/8	5.5	22	29	54	15.5	14	14
MPST10-G02		G1/4	7.5	26	29	58	15.5	17	14
MPST10-G03		G3/8	7.5	26	29	58	15.5	20	14
MPST10-G04		G1/2	10	28.5	29	60.5	15.5	24	14
MPST12-G02	12	G1/4	7.5	25.5	30	58.7	17.5	17	17
MPST12-G03		G3/8	7.5	27	30	60.2	17.5	20	17
MPST12-G04		G1/2	10	29.5	30	62.7	17.5	24	17

MPMF

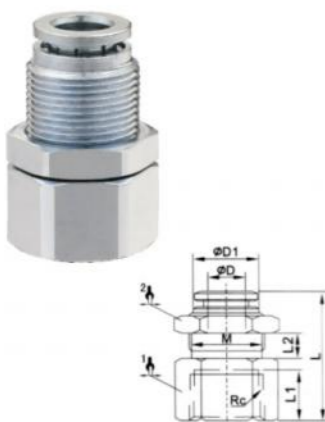

型号/MODEL	ΦD	Rc	L	L1	L2	ΦD1	1↻	2↻	M
MPMF04-01	4	Rc1/8	23	8.5	6	8.5	14	14	M10×1
MPMF04-02		Rc1/4	25.5	11	6	8.5	17	14	M10×1
MPMF06-01	6	Rc1/8	28	8.5	7	11.5	17	17	M14×1
MPMF06-02		Rc1/4	30.5	11	7	11.5	17	17	M14×1
MPMF06-03		Rc3/8	31.5	12	7	11.5	21	17	M14×1
MPMF08-01	8	Rc1/8	29	8.5	7.5	13.5	19	19	M16×1
MPMF08-02		Rc1/4	31.5	11	7.5	13.5	19	19	M16×1
MPMF08-03		Rc3/8	32.5	12	7.5	13.5	21	19	M16×1
MPMF08-04		Rc1/2	34.5	14	7.5	13.5	14	19	M16×1
MPMF10-01	10	Rc1/8	31	8.5	9.5	15.5	21	21	M18×1
MPMF10-02		Rc1/4	33.5	11	9.5	15.5	21	21	M18×1
MPMF10-03		Rc3/8	34.5	12	9.5	15.5	21	21	M18×1
MPMF10-04		Rc1/2	36.5	14	9.5	15.5	24	21	M18×1
MPMF12-02	12	Rc1/4	35	11	10	17.5	24	24	M20×1
MPMF12-03		Rc3/8	36	12	10	17.5	24	24	M20×1
MPMF12-04		Rc1/2	38	14	10	17.5	24	24	M20×1

MPH

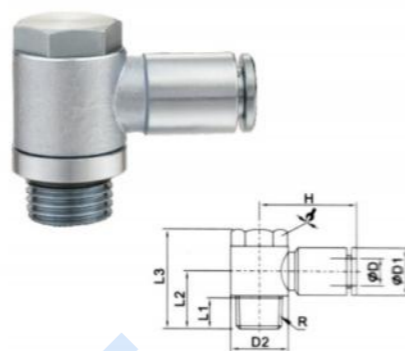

型号/MODEL	ΦD	R	L1	L2	L3	ΦD1	ΦD2	H	↻
MPH04-01	4	R1/8	7.5	15.5	26.5	8.5	13	22	12
MPH04-02		R1/4	9.5	17.5	30	8.5	16.5	23.5	14
MPH06-01	6	R1/8	7.5	15.5	26.5	11.5	13	26.5	12
MPH06-02		R1/4	9.5	17.5	30	11.5	16.5	27.5	14
MPH08-01	8	R1/8	7.5	15.5	26.5	13.5	13	27.5	12
MPH08-02		R1/4	9.5	17.5	30	13.5	16.5	30	14
MPH08-03		R3/8	10.5	19	32.5	13.5	21	32	19
MPH08-04	10	R3/8	10.5	19	32.5	15.5	21	35	19

MPH-G

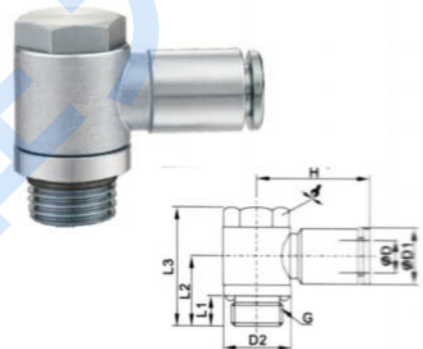

型号/MODEL	ΦD	G	L1	L2	L3	ΦD1	ΦD2	H	↻
MPH04-G01	4	G1/8	5.5	15.5	26.5	8.5	14	22	12
MPH04-G02		G1/4	6.5	17.5	30	8.5	17	23.5	14
MPH06-G01	6	G1/8	5.5	15.5	26.5	11.5	14	26.5	12
MPH06-G02		G1/4	6.5	17.5	30	11.5	17	27.5	14
MPH08-G01	8	G1/8	5.5	15.5	26.5	13.5	14	27.5	12
MPH08-G02		G1/4	6.5	17.5	30	13.5	17	30	14
MPH08-G03		G3/8	7.5	17.5	31	13.5	21	32	19
MPH08-G04	10	G3/8	7.5	17.5	31	15.5	21	35	19

MBCF



型号/MODEL	ΦD	G	L	L1	1↻	2↻
MBCF04-01	4/2.5	G1/8	20	8.5	8	14
MBCF06-01	6/4	G1/8	22	8.5	12	14
MBCF06-02		G1/4	25	11.5	12	17
MBCF08-01	8/6	G1/8	23	8.5	14	14
MBCF08-02		G1/4	26	11.5	14	17
MBCF08-03		G3/8	27	12.5	14	21
MBCF10-02	10/8	G1/4	27	11.5	16	17
MBCF10-03		G3/8	28	12.5	16	21
MBCF10-04		G1/2	31	15.5	16	24
MBCF12-02	12/10	G1/4	27	11.5	18	17
MBCF12-03		G3/8	28	12.5	18	21
MBCF12-04	G1/2	31	15.5	18	24	

MBL

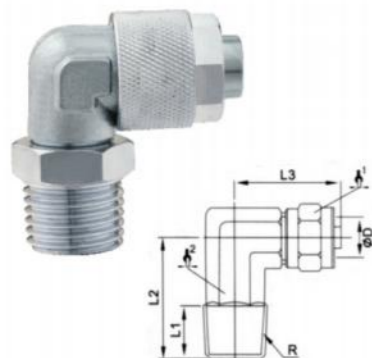

型号/MODEL	ΦD	R	L1	L2	L3	1	2
MBL04-01	4/2.5	R1/8	7.5	15	18.5	8	10
MBL06-01	6/4	R1/8	7.5	19	22	12	10
MBL06-02		R1/4	9.5	21	22	12	10
MBL08-01	8/6	R1/8	7.5	19	24	14	14
MBL08-02		R1/4	9.5	21	24	14	14
MBL08-03		R3/8	10.5	22	24	14	14
MBL10-02	10/8	R1/4	9.5	22	26	16	14
MBL10-03		R3/8	10.5	23	26	16	14
MBL10-04		R1/2	13.5	26	26	16	14
MBL12-02	12/10	R1/4	9.5	22	28	18	14
MBL12-03		R3/8	10.5	23	28	18	14
MBL12-04		R1/2	13.5	26	28	18	14

MBUT

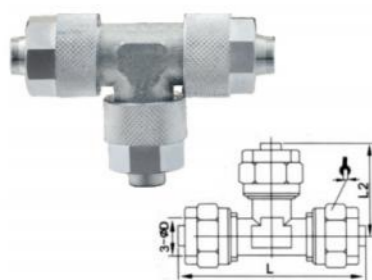

型号/MODEL	ΦD	L1	L2	2
MBUT04	4/2.5	37	18.5	8
MBUT06	6/4	44	22	12
MBUT08	8/6	48	24	14
MBUT10	10/8	52	26	16
MBUT12	12/10	54	28	18

MBUL

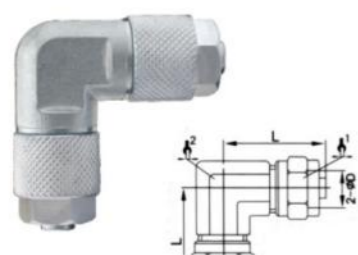

型号/MODEL	ΦD	L1	1	2
MBUL04	4/2.5	18.5	8	10
MBUL06	6/4	22	12	10
MBUL08	8/6	24	14	14
MBUL10	10/8	26	16	14
MBUL12	12/10	28	18	14

MBC



型号/MODEL	ΦD	R	L	L1	1	2
MBC04-01	4/2.5	R1/8	22	7.5	8	10
MBC04-02		R1/4	24	9.5	8	14
MBC06-01	6/4	R1/8	24	7.5	12	10
MBC06-02		R1/4	26	9.5	12	14
MBC06-03		R3/8	27.5	10.5	12	17
MBC08-01	8/6	R1/8	26	7.5	14	10
MBC08-02		R1/4	28	9.5	14	14
MBC08-03		R3/8	29	10.5	14	17
MBC10-02	10/8	R1/4	28.5	9.5	16	14
MBC10-03		R3/8	29.5	10.5	16	17
MBC10-04		R1/2	32.5	13.5	16	21
MBC12-02	12/10	R1/4	28.5	9.5	18	17
MBC12-03		R3/8	29.5	10.5	18	17
MBC12-04		R1/2	32.5	13.5	18	21

MBT

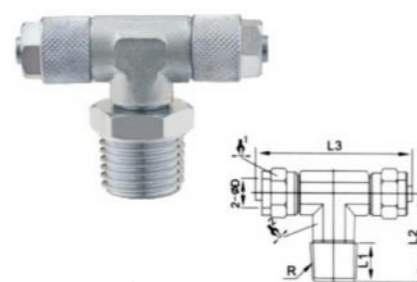

型号/MODEL	ΦD	R	L1	L2	L3	1	2
MBT04-01	4/2.5	R1/8	7.5	15	37	8	10
MBT06-01	6/4	R1/8	7.5	19	44	12	10
MBT06-02		R1/4	9.5	21	44	12	10
MBT08-01	8/6	R1/8	7.5	29	48	14	14
MBT08-02		R1/4	9.5	21	48	14	14
MBT08-03		R3/8	10.5	22	48	14	14
MBT10-02	10/8	R1/4	9.5	22	52	16	14
MBT10-03		R3/8	10.5	23	52	16	14
MBT10-04		R1/2	13.5	26	52	16	14
MBT12-02	12/10	R1/4	9.5	22	54	18	14
MBT12-03		R3/8	10.5	23	54	18	14
MBT12-04		R1/2	13.5	26	54	18	14

MBU

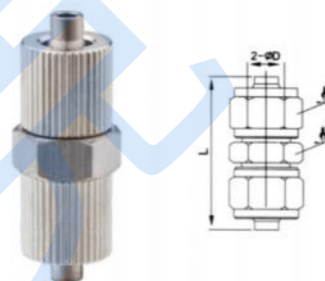

型号/MODEL	ΦD	L	1	2
MBU04	4/2.5	33	8	8
MBU06	6/4	30	12	12
MBU08	8/6	34	14	14
MBU10	10/8	36	16	14
MBU12	12/10	36	18	17

MBF



型号/MODEL	G	G1	L	1
MBF01G	G1/8	G1/8	17	14
MBF02G	G1/4	G1/4	23	17
MBF03G	G3/8	G3/8	25.5	21
MBF04G	G1/2	G1/2	30	24
MBF02G-01G	G1/4	G1/8	22	17
MBF03G-02G	G3/8	G1/4	24	21

MBM

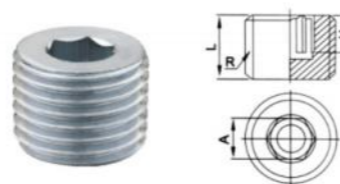

型号/MODEL	R	L	H	A
MBM01	R1/8	8	4.5	5
MBM02	R1/4	10	5.5	6
MBM03	R3/8	11	6	8
MBM04	R1/2	13.5	8	10

MBB



型号/MODEL	G	L	L1	1
MBB01G-01G	G1/8	18	5.5	14
MBB02G-02G	G1/4	23	7.5	17
MBB03G-03G	G3/8	23	7.5	21
MBB04G-04G	G1/2	28	10	24

型号/MODEL	R	L	L1	1
MBB01T-01T	R1/8	21	8.0	10
MBB02T-02T	R1/4	25	10	14
MBB03T-03T	R3/8	27.5	11	17
MBB04T-04T	R1/2	34	14	21

BLFM1



产品编号 Item No.	产品规格 Measurement 内×外	牌价 Iprice
BLFM1-0101	1/8"×1/8"	48
BLFM1-0102	1/8"×1/4"	56
BLFM1-0201	1/4"×1/8"	56
BLFM1-0202	1/4"×1/4"	56
BLFM1-0203	1/4"×3/8"	100
BLFM1-0302	3/8"×1/4"	100
BLFM1-0303	3/8"×3/8"	100
BLFM1-0404	1/2"×1/2"	200

BTF2



产品编号 Item No.	产品规格 Measurement 内×外	牌价 Iprice
BTF2-001	1/8"	48
BTF2-002	1/4"	48
BTF2-003	3/8"	75
BTF2-004	1/2"	190

BLF



产品编号 Item No.	产品规格 Measurement 内×外	牌价 Iprice
BLF-001	1/8"	48
BLF-002	1/4"	56
BLF-003	3/8"	90
BLF-004	1/2"	160

B4F



产品编号 Item No.	产品规格 Measurement 内×外	牌价 Iprice
B4F-001	1/8"	75
B4F-002	1/4"	75
B4F-003	3/8"	95

BLF1



产品编号 Item No.	产品规格 Measurement 内×外	牌价 Iprice
BLF1-001	1/8"	48
BLF1-002	1/4"	56
BLF1-003	3/8"	100
BLF1-004	1/2"	

BTFM2



产品编号 Item No.	产品规格 Measurement 内×外	牌价 Iprice
BTFM2-0101	1/8"×1/8"	55
BTFM2-0202	1/4"×1/4"	65
BTFM2-0303	3/8"×3/8"	90

BTM



产品编号 Item No.	产品规格 Measurement 内×外	牌价 Iprice
BTM-001	1/8"	65
BTM-002	1/4"	70
BTM-003	3/8"	80
BTM-004	1/2"	180

BLN



产品编号 Item No.	产品规格 Measurement 内×外	牌价 Iprice
BLN-0101	1/8"×1/8"	48
BLN-0201	1/4"×1/8"	48
BLN-0202	1/4"×1/4"	48
BLN-0301	3/8"×1/8"	56
BLN-0302	3/8"×1/4"	56
BLN-0303	3/8"×3/8"	56
BLN-0402	1/2"×1/4"	100
BLN-0403	1/2"×3/8"	100
BLN-0404	1/2"×1/2"	100
BLN-0604	3/4"×1/2"	210
BLN-0606	3/4"×3/4"	210

BTF



产品编号 Item No.	产品规格 Measurement 内×外	牌价 Iprice
BTF-001	1/8"	55
BTF-002	1/4"	80
BTF-003	3/8"	105
BTF-004	1/2"	170

BLFM



产品编号 Item No.	产品规格 Measurement 内×外	牌价 Iprice
BLFM-0101	1/8"×1/8"	48
BLFM-0102	1/8"×1/4"	56
BLFM-0201	1/4"×1/8"	56
BLFM-0202	1/4"×1/4"	56
BLFM-0302	3/8"×1/4"	100
BLFM-0303	3/8"×3/8"	100
BLFM-0304	1/2"×1/2"	200

BTF1



产品编号 Item No.	产品规格 Measurement 内×外	牌价 Iprice
BTF1-001	1/8"	80
BTF1-002	1/4"	100
BTF1-003	3/8"	180
BTF1-004	1/2"	180

BSNT



产品编号 Item No.	产品规格 Measurement 内×外	牌价 Iprice
BSNT-002	1/4"	11
BSNT-025	5/16"	14
BSNT-003	3/8"	24
BSNT-004	1/2"	32
BSNT-005	5/8"	60
BSNT-006	3/4"	80

BLS



产品编号 Item No.	产品规格 Measurement 内×外	牌价 Iprice
BLS-0201	1/4"×1/8"	44
BLS-0202	1/4"×1/4"	50
BLS-0203	1/4"×3/8"	58
BLS-0204	1/4"×1/2"	108
BLS-2501	5/16"×1/8"	52
BLS-2502	5/16"×1/4"	52
BLS-2503	5/16"×3/8"	58
BLS-2504	5/16"×1/2"	108
BLS-0302	3/8"×1/4"	58
BLS-0303	3/8"×3/8"	58
BLS-0304	3/8"×1/2"	108
BLS-0402	1/2"×1/4"	108
BLS-0403	1/2"×3/8"	108
BLS-0404	1/2"×1/2"	108
BLS-0504	5/8"×1/2"	200
BLS-0604	3/4"×1/2"	200
BLS-0406	1/2"×3/4"	200
BLS-0506	5/8"×3/4"	200
BLS-0606	3/4"×3/4"	200

BCS



产品编号 Item No.	产品规格 Measurement 内×外	牌价 Iprice
BCS-0201	1/4"×1/8"	28
BCS-0202	1/4"×1/4"	36
BCS-0203	1/4"×3/8"	44
BCS-0204	1/4"×1/2"	62
BCS-2501	5/16"×1/8"	38
BCS-2502	5/16"×1/4"	38
BCS-2503	5/16"×3/8"	44
BCS-2504	5/16"×1/2"	62
BCS-0302	3/8"×1/4"	38
BCS-0303	3/8"×3/8"	44
BCS-0304	3/8"×1/2"	62
BCS-0402	1/2"×1/4"	44
BCS-0403	1/2"×3/8"	62
BCS-0404	1/2"×1/2"	62
BCS-0504	5/8"×1/2"	80
BCS-0604	3/4"×1/2"	80
BCS-0406	1/2"×3/4"	120
BCS-0506	5/8"×3/4"	120
BCS-0606	3/4"×3/4"	120

BULS



产品编号 Item No.	产品规格 Measurement 内×外	牌价 Iprice
BULS-002	1/4"	52
BULS-025	5/16"	60
BULS-003	3/8"	68
BULS-004	1/2"	108
BULS-005	5/8"	200
BULS-006	3/4"	200

BUCS



产品编号 Item No.	产品规格 Measurement 内×外	牌价 Iprice
BUCS-002	1/4"	44
BUCS-025	5/16"	50
BUCS-003	3/8"	58
BUCS-004	1/2"	74
BUCS-005	5/8"	90
BUCS-006	3/4"	120

BTS



产品编号 Item No.	产品规格 Measurement 内×外	牌价 Iprice
BTS-0201	1/4"×1/8"	70
BTS-0202	1/4"×1/4"	78
BTS-0203	1/4"×3/8"	90
BTS-0204	1/4"×1/2"	170
BTS-2501	5/16"×1/8"	78
BTS-2502	5/16"×1/4"	78
BTS-2503	5/16"×3/8"	90
BTS-2504	5/16"×1/2"	170
BTS-0302	3/8"×1/4"	90
BTS-0303	3/8"×3/8"	90
BTS-0304	3/8"×1/2"	170
BTS-0402	1/2"×1/4"	90
BTS-0403	1/2"×3/8"	170
BTS-0404	1/2"×1/2"	170
BTS-0406	1/2"×3/4"	320
BTS-0506	5/8"×3/4"	320
BTS-0606	3/4"×3/4"	320

BUTS



产品编号 Item No.	产品规格 Measurement 内×外	牌价 Iprice
BUTS-002	1/4"	70
BUTS-025	5/16"	80
BUTS-003	3/8"	88
BUTS-004	1/2"	170
BUTS-005	5/8"	320
BUTS-006	3/4"	320

BSTS



BCH



产品编号 Item No.	产品规格 Measurement 内×外	牌价 Iprice
BCH-1501	3/16" × 1/8"	18
BCH-1502	3/16" × 1/4"	21
BCH-0201	1/4" × 1/8"	16
BCH-0202	1/4" × 1/4"	20
BCH-0203	1/4" × 3/8"	24
BCH-0204	1/4" × 1/2"	34
BCH-2501	5/16" × 1/8"	15
BCH-2502	5/16" × 1/4"	16
BCH-2503	5/16" × 3/8"	24
BCH-2504	5/16" × 1/2"	34
BCH-0301	3/8" × 1/8"	16
BCH-0302	3/8" × 1/4"	20
BCH-0303	3/8" × 3/8"	26
BCH-0304	3/8" × 1/2"	34
BCH-0401	1/2" × 1/8"	21
BCH-0402	1/2" × 1/4"	22
BCH-0403	1/2" × 3/8"	30
BCH-0404	1/2" × 1/2"	36
BCH-0503	5/8" × 3/8"	32
BCH-0504	5/8" × 1/2"	42
BCH-0506	5/8" × 3/4"	90
BCH-0604	3/4" × 1/2"	60
BCH-0606	3/4" × 3/4"	90
BCH-0608	3/4" × 1"	220
BCH-0806	1" × 3/8"	120
BCH-0808	1" × 1"	220

BLH



产品编号 Item No.	产品规格 Measurement 内×外	牌价 Iprice
BLH-0201	1/4" × 1/8"	48
BLH-0202	1/4" × 1/4"	48
BLH-0203	1/4" × 3/8"	56
BLH-2501	5/16" × 1/8"	48
BLH-2502	5/16" × 1/4"	48
BLH-2503	5/16" × 3/8"	56
BLH-2504	5/16" × 1/2"	100
BLH-0301	3/8" × 1/8"	48
BLH-0302	3/8" × 1/4"	48
BLH-0303	3/8" × 3/8"	56
BLH-0304	3/8" × 1/2"	100
BLH-0402	1/2" × 1/4"	100
BLH-0403	1/2" × 3/8"	100
BLH-0404	1/2" × 1/2"	100
BLH-0503	5/8" × 3/8"	100
BLH-0504	5/8" × 1/2"	100
BLH-0506	5/8" × 3/4"	
BLH-0604	3/4" × 1/2"	
BLH-0606	3/4" × 3/4"	
BLH-0608	3/4" × 1"	
BLH-0806	1" × 3/8"	
BLH-0808	1" × 1"	

BYH



产品编号 Item No.	产品规格 Measurement 内×外	牌价 Iprice
BYH-015	3/16"	60
BYH-002	1/4"	60
BYH-025	5/16"	35
BYH-003	3/8"	55
BYH-004	1/2"	90

BTH



产品编号 Item No.	产品规格 Measurement 内×外	牌价 Iprice
BTH-015	3/16"	60
BTH-002	1/4"	60
BTH-025	5/16"	35
BTH-003	3/8"	55
BTH-004	1/2"	90

B4H



产品编号 Item No.	产品规格 Measurement 内×外	牌价 Iprice
B4H-015	3/16"	120
B4H-002	1/4"	120
B4H-025	5/16"	90
B4H-003	3/8"	120
B4H-004	1/2"	140

BCHF



产品编号 Item No.	产品规格 Measurement 内×外	牌价 Iprice
BCHF-0201	1/4" × 1/8"	30
BCHF-0202	1/4" × 1/4"	30
BCHF-0203	1/4" × 3/8"	48
BCHF-2501	5/16" × 1/8"	30
BCHF-2502	5/16" × 1/4"	30
BCHF-2503	5/16" × 3/8"	48
BCHF-2504	5/16" × 1/2"	60
BCHF-0301	3/8" × 1/8"	30
BCHF-0302	3/8" × 1/4"	30
BCHF-0303	3/8" × 3/8"	48
BCHF-0304	3/8" × 1/2"	60
BCHF-0403	1/2" × 3/8"	80
BCHF-0404	1/2" × 1/2"	80
BCHF-0504	5/8" × 1/2"	85
BCHF-0604	3/4" × 1/2"	90

BHH



产品编号 Item No.	产品规格 Measurement 内×外	牌价 Iprice
BHH-015	3/16"	10
BHH-002	1/4"	12
BHH-025	5/16"	14
BHH-003	3/8"	20
BHH-004	1/2"	30
BHH-005	5/8"	70
BHH-006	3/4"	75

BFM



产品编号 Item No.	产品规格 Measurement 内×外	牌价 Iprice
BFM-0101	1/8" × 1/8"	20
BFM-0102	1/8" × 1/4"	20
BFM-0201	1/4" × 1/8"	24
BFM-0202	1/4" × 1/4"	24
BFM-0203	1/4" × 3/8"	24
BFM-0301	3/8" × 1/8"	35
BFM-0302	3/8" × 1/4"	35
BFM-0303	3/8" × 3/8"	35
BFM-0304	3/8" × 1/2"	35
BFM-0402	1/2" × 1/4"	50
BFM-0403	1/2" × 3/8"	50
BFM-0404	1/2" × 1/2"	50

BBU



产品编号 Item No.	产品规格 Measurement 内×外	牌价 Iprice
BBU-0201	1/4" × 1/8"	12
BBU-0301	3/8" × 1/8"	16
BBU-0302	3/8" × 1/4"	18
BBU-0401	1/2" × 1/8"	30
BBU-0402	1/2" × 1/4"	25
BBU-0403	1/2" × 3/8"	24
BBU-0602	3/4" × 1/4"	50
BBU-0603	3/4" × 3/8"	45
BBU-0604	3/4" × 1/2"	45
BBU-0804	1" × 1/2"	100
BBU-0806	1" × 3/4"	100

BCF



产品编号 Item No.	产品规格 Measurement 内×外	牌价 Iprice
BCF-0101	1/8" × 1/8"	20
BCF-0201	1/4" × 1/8"	24
BCF-0202	1/4" × 1/4"	24
BCF-0302	3/8" × 1/4"	32
BCF-0303	3/8" × 3/8"	32
BCF-0402	1/2" × 1/4"	50
BCF-0403	1/2" × 3/8"	50
BCF-0404	1/2" × 1/2"	50

BCN



产品编号 Item No.	产品规格 Measurement 内×外	牌价 Iprice
BCN-0101	1/8" × 1/8"	14
BCN-0201	1/4" × 1/8"	14
BCN-0202	1/4" × 1/4"	14
BCN-0301	3/8" × 1/8"	22
BCN-0302	3/8" × 1/4"	22
BCN-0303	3/8" × 3/8"	22
BCN-0402	1/2" × 1/4"	32
BCN-0403	1/2" × 3/8"	32
BCN-0404	1/2" × 1/2"	32
BCN-0604	3/4" × 1/2"	90
BCN-0606	3/4" × 3/4"	90
BCN-0806	1" × 3/8"	190
BCN-0808	1" × 1"	190

BP



产品编号 Item No.	产品规格 Measurement 内×外	牌价 Iprice
BP-001	1/8"	10
BP-002	1/4"	14
BP-003	3/8"	18
BP-004	1/2"	25
BP-006	3/4"	50

转牙式



产品编号 Item No.	产品规格 Measurement 内×外	牌价 Iprice
BP-1	5/16" × 1/4" T	16
BP-2	1/4" × 1/4" T	16
BP-3	3/8" × 3/8" T	50
BP-4	1/2" × 1/2" T	

洗车机专用头



产品编号 Item No.	产品规格 Measurement 内×外	牌价 Iprice
CWHH-7.5	7.5m/m	55
CWHH-8.5	8.5m/m	60
CWHH-10	10m/m	120
CWHH-13	13m/m	230

空压机专用头



产品编号 Item No.	产品规格 Measurement 内×外	牌价 Iprice
CWHH-2502	5/16" × 1/4" T	100
CWHH-0302	3/8" × 1/4" T	100

饮水机专用头



产品编号 Item No.	产品规格 Measurement 内×外	牌价 Iprice
WBFM-0400	1/2" 无孔	160
WBFM-0402	1/2" 有孔	170
WBFM-0600	3/4" 无孔	190
WBFM-0402	3/4" 有孔	200

BSLV



产品编号 Item No.	产品规格 Measurement 内×外	牌价 Iprice
BSLV-001	1/8"	3
BSLV-002	1/4"	4
BSLV-025	5/16"	5
BSLV-003	3/8"	6
BSLV-004	1/2"	8
BSLV-006	3/4"	
BSLV-008	1"	

45° 接头



产品编号 Item No.	产品规格 Measurement 内×外	牌价 Iprice
01	1/8"	
02	1/4"	
03	3/8"	
04	1/2"	

BCM



产品编号 Item No.	产品规格 Measurement 内 × 外	牌价 Iprice
BCM-1501	3/16" × 1/8"	70
BCM-0201	1/4" × 1/8"	28
BCM-0202	1/4" × 1/4"	36
BCM-0203	1/4" × 3/8"	44
BCM-0204	1/4" × 1/2"	62
BCM-2501	5/16" × 1/8"	38
BCM-2502	5/16" × 1/4"	38
BCM-2503	5/16" × 3/8"	44
BCM-2504	5/16" × 1/2"	62
BCM-0301	3/8" × 1/8"	38
BCM-0302	3/8" × 1/4"	38
BCM-0303	3/8" × 3/8"	44
BCM-0304	3/8" × 1/2"	62
BCM-0402	1/2" × 1/4"	62
BCM-0403	1/2" × 3/8"	62
BCM-0404	1/2" × 1/2"	62
BCM-0504	5/8" × 1/2"	155
BCM-0506	5/8" × 3/4"	235
BCM-0604	3/4" × 1/2"	205
BCM-0606	3/4" × 3/4"	335

BLM



产品编号 Item No.	产品规格 Measurement 内 × 外	牌价 Iprice
BLM-1501	3/16" × 1/8"	83
BLM-0201	1/4" × 1/8"	50
BLM-0202	1/4" × 1/4"	50
BLM-0203	1/4" × 3/8"	58
BLM-0204	1/4" × 1/2"	108
BLM-2501	5/16" × 1/8"	50
BLM-2502	5/16" × 1/4"	52
BLM-2503	5/16" × 3/8"	58
BLM-2504	5/16" × 1/2"	108
BLM-0301	3/8" × 1/8"	58
BLM-0302	3/8" × 1/4"	58
BLM-0303	3/8" × 3/8"	58
BLM-0304	3/8" × 1/2"	108
BLM-0402	1/2" × 1/4"	108
BLM-0403	1/2" × 3/8"	108
BLM-0404	1/2" × 1/2"	108
BLM-0504	5/8" × 1/2"	326
BLM-0506	5/8" × 3/4"	460
BLM-0604	3/4" × 1/2"	395
BLM-0606	3/4" × 3/4"	460

BUCM



产品编号 Item No.	产品规格 Measurement 内 × 外	牌价 Iprice
BUCM-002	1/4"	44
BUCM-025	5/16"	50
BUCM-003	3/8"	58
BUCM-004	1/2"	74
BUCM-10M	10m/m	58
BUCM-12M	12m/m	74
BUCM-005	5/8"	232
BUCM-006	3/4"	330

BUTM



产品编号 Item No.	产品规格 Measurement 内 × 外	牌价 Iprice
BUTM-002	1/4"	70
BUTM-025	5/16"	80
BUTM-003	3/8"	88
BUTM-004	1/2"	198
BUTM-10M	10m/m	88
BUTM-12M	12m/m	198
BUTM-005	5/8"	555
BUTM-006	3/4"	690

BCMF



产品编号 Item No.	产品规格 Measurement 内 × 外	牌价 Iprice
BCMF-0201	1/4" × 1/8"	46
BCMF-0202	1/4" × 1/4"	46
BCMF-0203	1/4" × 3/8"	64
BCMF-2502	5/16" × 1/4"	48
BCMF-2503	5/16" × 3/8"	64
BCMF-0302	3/8" × 1/4"	48
BCMF-0303	3/8" × 3/8"	64
BCMF-0304	3/8" × 1/2"	90
BCMF-0402	1/2" × 1/4"	90
BCMF-0403	1/2" × 3/8"	90
BCMF-0404	1/2" × 1/2"	90

BTM



产品编号 Item No.	产品规格 Measurement 内 × 外	牌价 Iprice
BTM-0201	1/4" × 1/8"	70
BTM-0202	1/4" × 1/4"	70
BTM-0203	1/4" × 3/8"	90
BTM-0204	1/4" × 1/2"	180
BTM-2501	5/16" × 1/8"	78
BTM-2502	5/16" × 1/4"	78
BTM-2503	5/16" × 3/8"	90
BTM-2504	5/16" × 1/2"	180
BTM-0301	3/8" × 1/8"	90
BTM-0302	3/8" × 1/4"	90
BTM-0303	3/8" × 3/8"	90
BTM-0304	3/8" × 1/2"	180
BTM-0402	1/2" × 1/4"	180
BTM-0403	1/2" × 3/8"	180
BTM-0404	1/2" × 1/2"	180

BSTM



BULM



产品编号 Item No.	产品规格 Measurement 内 × 外	牌价 Iprice
BULM-002	1/4"	52
BULM-025	5/16"	60
BULM-003	3/8"	68
BULM-004	1/2"	120
BULM-10M	10m/m	68
BULM-12M	12m/m	120
BULM-005	5/8"	330
BULM-006	3/4"	460

BLMF



产品编号 Item No.	产品规格 Measurement 内 × 外	牌价 Iprice
BLMF-0201	1/4" × 1/8"	50
BLMF-0202	1/4" × 1/4"	58
BLMF-0203	1/4" × 3/8"	108
BLMF-2501	5/16" × 1/8"	58
BLMF-2502	5/16" × 1/4"	58
BLMF-2503	5/16" × 3/8"	108
BLMF-0303	3/8" × 3/8"	108



DIAMIK
戴维克

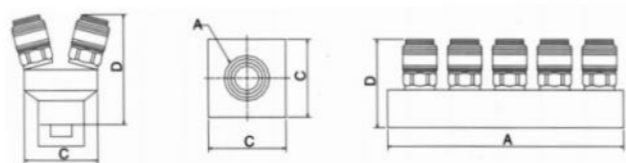

型号model	A	B	C	D
JH2A	28		45	68
JH3A	28		55	68
JH4B	125		24	55
JH5B	155		24	55
JH6B	185		24	55



型号model	尺寸dimension				装箱数量 Per carton(PCS)	毛量/净重 G.W/N.Wkg
	PT	D	S	L		
JH2A	PT1/4	6	20	59.2	100(10×10)	9.8/8.6
JH3A	PT3/8	8	20	60	100(10×10)	9.5/9
JH4B	PT1/2	10	22	60	100(10×10)	11/11

型号model	尺寸dimension								装箱数量 Per carton(PCS)	毛量/净重 G.W/N.Wkg
	D1	D2	D3	L1	L2	L3	S	PT		
JH2A	7	10.95	13.05	5.5	21	38.5	14	PT1/4	200(10×20)	5.9/5.4
JH3A	7	10.95	13.05	5.5	21	39	20	PT3/8	200(10×20)	8.9/8.4
JH4B	7	10.95	13.05	5.5	21	40	24	PT1/2	200(10×20)	9.9/9.4



型号model	尺寸dimension				装箱数量 Per carton(PCS)	毛量/净重 G.W/N.Wkg
	PT	D	S	L		
SF202	PT1/4	8	20	58	100(10×10)	10.2/9.7
SF203	PT3/8	8	20	58	100(10×10)	9.5/9
SF204	PT1/2	8	24	59	100(10×10)	11/11.5

型号model	尺寸dimension								装箱数量 Per carton(PCS)	毛量/净重 G.W/N.Wkg
	D1	D2	D3	L1	L2	L3	S	PT		
PF602	7	10.95	13.05	5.5	21	35	14	PT1/4	200(10×20)	8.7/8.2
PF603	7	10.95	13.05	5.5	21	35	20	PT3/8	200(10×20)	7.1/6.6
PF604	7	10.95	13.05	5.5	21	36.5	24	PT1/2	200(10×20)	8.5/8.0

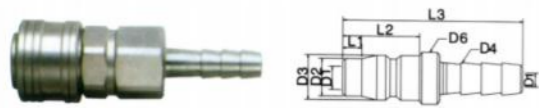

型号model	尺寸dimension				装箱数量 Per carton(PCS)	毛量/净重 G.W/N.Wkg
	D1	D2	S	L		
SH302For1/8"Hose	3.5	7	20	76.5	100(10×10)	8.5/8
SH303For1/4"Hose	5	9	20	76.5	100(10×10)	8.8/8.3
SH304For3/8"Hose	6	11	22	76.5	100(10×10)	9.2/8.7

型号model	尺寸dimension								装箱数量 Per carton(PCS)	毛量/净重 G.W/N.Wkg
	D1	D2	D3	D4	D5	L1	L2	L3		
PH702For1/8"Hose	3.5	10.95	13.05	7	15	5.5	21	56.5	200(10×20)	8.7/8.2
PH703For1/4"Hose	5	10.95	13.05	9	15	5.5	21	56.5	200(10×20)	7.1/6.6
PH704For3/8"Hose	6	10.95	13.05	11	15	5.5	21	56.5	200(10×20)	8.5/8.0



型号model	尺寸dimension				装箱数量 Per carton(PCS)	毛量/净重 G.W/N.Wkg
	D2	D	S	L		
SA402 5×8	7	3.5	20	68	100(10×10)	9.6/8.9
SA403 6.5×10	9	5	20	69	100(10×10)	8.8/8.3
SA404 8×12	11	7	22	70	100(10×10)	10.3/9.8

型号model	尺寸dimension								装箱数量 Per carton(PCS)	毛量/净重 G.W/N.Wkg
	D1	D2	D3	D4	S	L1	L2	L3		
PA802 5×8	3	10.95	13.05	7	14	5.5	21	41.5	200(10×20)	5.9/5.4
PA803 6.5×10	5	10.95	13.05	9	16	5.5	21	42.5	200(10×20)	6.9/6.4
PA804 8×12	7	10.95	13.05	11	18	5.5	21	43.5	200(10×20)	7.9/7.4

PP

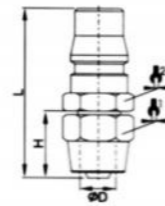

型号/MODEL	ΦD	H	L	1	2
PP 8×5	8/5	14	38	14	14
PP 10×6.5	10/6.5	14	38.5	15	14
PP 12×8	12/8	15	38	17.5	15

HN

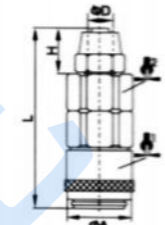
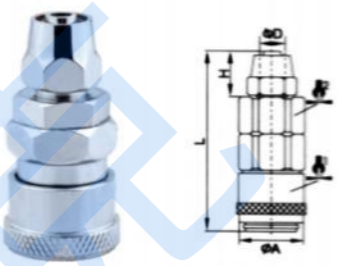

型号/MODEL	ΦD	H	L	ΦA	1	2
HN 8×5	8/5	14	58	21	14	19.5
HN 10×6.5	10/6.5	14	58	21	15	19.5
HN 12×8	12/8	15	58	21	17.5	19.5

CH

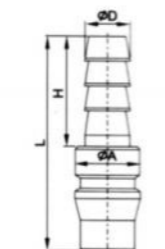

型号/MODEL	ΦD	ΦA	H	L
CH 8×5	8/5	13.5	25	50
CH 10×6.5	10/6.5	13.5	23	45
CH 12×8	12/8	13.5	23	44.5

HH

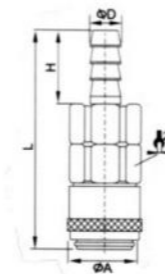

型号/MODEL	ΦD	H	L	ΦA	1
HH 8×5	8/5	21.5	64.5	21	19.5
HH 10×6.5	10/6.5	24.5	68	21	19.5
HH 12×8	12/8	24	58	21	19.5

CM

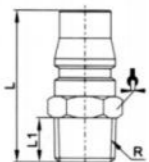

型号/MODEL	R	L1	L	1
CM 02	R1/4	11	34	14
CM 03	R3/8	12	35	17
CM 04	R1/2	14	40	21

HM

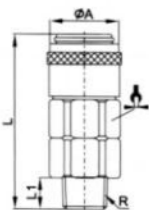

型号/MODEL	R	L1	L	ΦA	1
HM 02	R1/4	11	55.5	21	19.5
HM 03	R3/8	12	54	21	19.5
HM 04	R1/2	14	56	21	19.5

CF

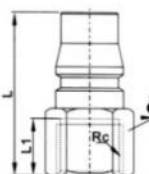

型号/MODEL	Rc	L1	L	1
CF 02	Rc1/4	12	33	15
CF 03	Rc3/8	12	33.3	19
CF 04	Rc1/2	12.5	33.7	23

HF

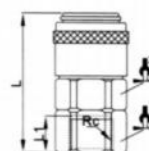

型号/MODEL	Rc	L1	L	ΦA	1	2
HF 02	Rc1/4	12	45	21	19	21
HF 03	Rc3/8	12	55.5	21	19.5	19.5
HF 04	Rc1/2	12.5	50.5	21	23	19.5

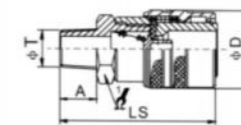

PART NO.	LS	ΦD	1	A	T
KLRM-02SM	52.5	25	19	12	1/4
KLRM-03SM	52.5	25	19	13	3/8
KLRM-04SM	52.5	25	22	15	1/2

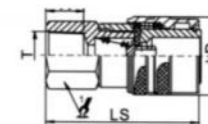

PART NO.	LS	ΦD	1	A	T
KLRM-02SF	49.5	25	19	12	1/4
KLRM-03SF	49.5	25	19	13	3/8
KLRM-04SF	49.5	25	24	15	1/2

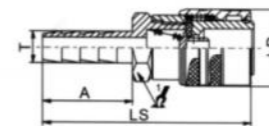

PART NO.	LS	ΦD	1	A	T
KLRM-02SH	69	25	19	28	9
KLRM-03SH	69	25	19	30	10.5
KLRM-04SH	69	25	19	30	13

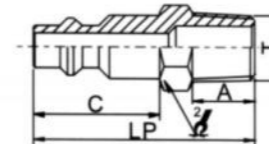

PART NO.	LP	C	2	A	T
KLRM-02PM	42	24	14	12	1/4
KLRM-03PM	43	24	17	13	3/8
KLRM-04PM	45	24	22	15	1/2

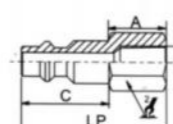

PART NO.	LP	C	2	A	T
KLRM-02PF	39	24	17	12	1/4
KLRM-03PF	39	24	19	13	3/8
KLRM-04PF	41	24	24	15	1/2

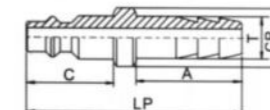

PART NO.	LP	C	CP	A	T
KLRM-02PH	57	24	Φ19	28	9
KLRM-03PH	59	24	Φ19	30	10.5
KLRM-04PH	59	24	Φ19	30	13

SOCKET PLUG

连接器装配/COUPLING FITTING

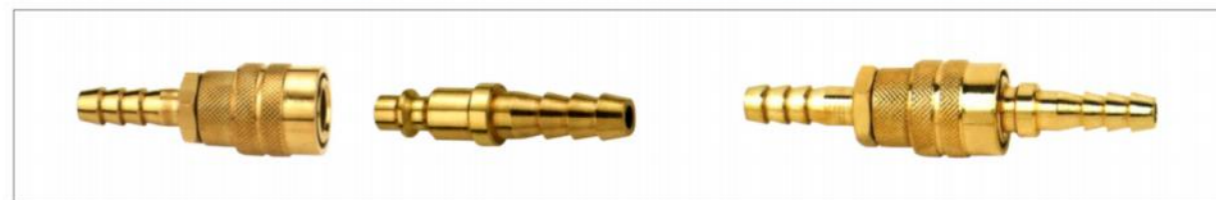

应用: 气动工具, 汽车制造, 压缩空气, 工程机械, 压缩机。

互换性: 与派克(Paeker)20系列, 利达时(RECTUS)23KA系列, 汉森(HANSEN)3000系列, 希恩(CEJN)310系列。

用途与特点: 本接头适用于以油、水、空气为介质的场合。公称压力为1.5Mpa, 介质温度为-20℃~+80℃。

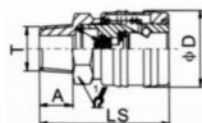

PART NO.	LS	ΦD	1	A	T
KLRO-02SM	46.5	26.8	22	11.5	1/4
KLRO-03SM	47.5	26.8	22	12.5	3/8

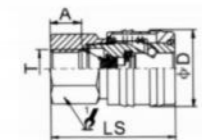

PART NO.	LS	ΦD	1	A	T
KLRO-02SF	43.5	26.8	22	9	1/4
KLRO-03SF	43.5	26.8	22	11	3/8

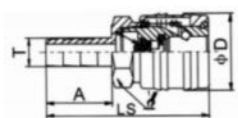

PART NO.	LS	ΦD	1	A	T
KLRO-02SH	54.5	26.8	22	25	7
KLRO-03SH	54.5	26.8	22	25	9

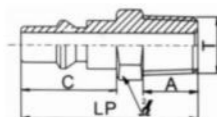

PART NO.	LP	C	2	A	T
KLRO-02PM	40.5	22	14	11.5	1/4
KLRO-03PM	40.5	22	17	12.5	3/8

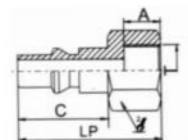

PART NO.	LP	C	2	A	T
KLRO-02PF	35	22	17	9	1/4
KLRO-03PF	37	22	19	11	3/8

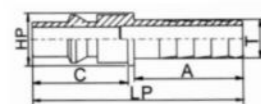

PART NO.	LP	C	HP	A	T
KLRO-02PH	48.5	22	12	25	7
KLRO-03PH	48.5	22	14	25	9

SOCKET PLUG

连接器装配/COUPLING FITTING



应用：单手操作，钢质销针自锁，气动工具，机械设备。

互换性：与派克(Paeker)50系列,利达时(RECTUS)22KA系列，希思(CEJN)300系列。

用途与特点：本接头适用于以油、水、空气为介质的场合。公称压力为1.5Mpa,介质温度为-20℃~+80℃。

应用程序/APPLICATIONS

用于使用气动管道的设备的螺母拧紧管道连接工具

特点/FEATURES

连接方式为螺母拧紧,在有振动的环境中有效。
由塑料制成,具有半永久性,具有良好的耐腐蚀性和耐化学品性。
适用于低气压设备

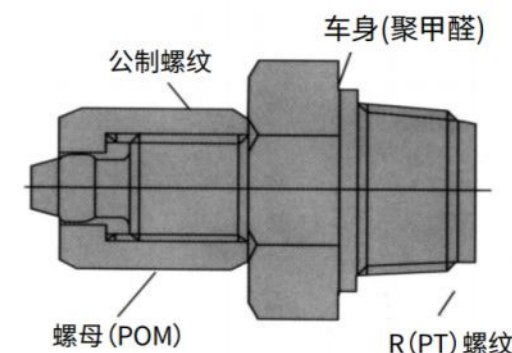

规格/SPECIFICATIONS

流体类型:空气(无其他气体或液体) 工作压力:0~150PSI/0~9.9KGF/CM (0~990KPA)
负压:-29.5IN HG/-750MMHG (-750TORR) 工作温度:32~140°F/0~60°C 适用管:聚氨酯和尼龙。

METRIC-R						
产品编号	ΦD	T	L	A	H1	H2
CK06-01	6	R1/8	28.5	7.0	12	13
CK06-02		R1/4	30.5	9.0		15
CK08-01	8	R1/8	29.5	9.0	14	14
CK08-02		R1/4	29.0	9.0		15
CK08-03		R3/8	31.7	10.2		19
CK10-02	10	R1/4	34.4	9.2	17	17
CK10-03		R3/8	34.4	10.2		19
CK12-02	12	R1/4	39.0	9.2	19	17
CK12-03		R3/8	41.2	10.2		19

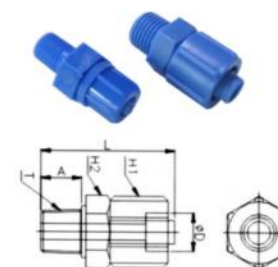

METRIC-R						
产品编号	ΦD	T	L	E	A	H1
GCK06-01	6	R1/8	24.5	26.5	7.0	12
GCK06-02		R1/4	26.5	29.5	9.0	
GCK08-01	8	R1/8	24.5	25.5	8.0	14
GCK08-02		R1/4	26.5	29.0	10.0	
GCK08-03		R3/8	27.5	32.5	11.0	
GCK10-02	10	R1/4	30.0	32.0	12.0	17
GCK10-03		R3/8	31.0	34.7	12.0	
GCK12-02	12	R1/4	32.0	41.5	11.0	19
GCK12-03		R3/8	34.2	41.5	12.0	

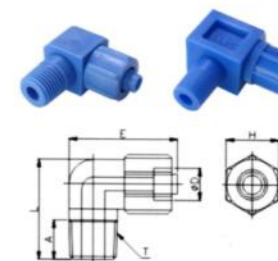

METRIC-R							
产品编号	ΦD	L	E	C	M1	M2	H
GCK06-01	6	31.1	48.3	4.3	5.7	11.2	12
GCK06-02	8	32.0	18.0	4.3	6.6	12.2	14
GCK08-01	10	40.0	54.0	4.3	8.3	13.4	17
GCK08-02	12	47.7	68.0	4.3	9.3	13.7	19

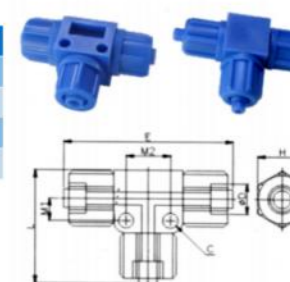

螺纹代号: BSPP BSPT NPT

A型消声器
A Type Series Muffler



产品代号 Code	螺纹 Screw thread		S mm
	尺寸 Size		
A-M5	M5		9
-6A	1/8"		13
-8A	1/4"		17
-10A	3/8"		22
-15A	1/2"		24
-20A	3/4"		30
-25A	1"		36
-32A	1 1/4"		46
-40A	1 1/2"		52
-50A	2"		64

B型消声器
B Type Series Muffler



产品代号 Code	螺纹 Screw thread		S mm
	尺寸 Size		
B-M5	M5		9
-6A	1/8"		12
-8A	1/4"		15
-10A	3/8"		19
-15A	1/2"		22
-20A	3/4"		27
-25A	1"		36

V型消声器
V Type Series Muffler



产品代号 Code	螺纹 Screw thread		S mm
	尺寸 Size		
V-M5	M5		8
V-6	1/8"		12
V-8	1/4"		15
V-10	3/8"		19
V-15	1/2"		22
V-20	3/4"		30
V-25	1"		36

插入式消声器
Inserting Type Muffler



产品代号 Code	规格 Spec	
	ΦD × Φd	
B15	10 × 2.5	
B16	13 × 3	
B17	13 × 4	
B18	17 × 6	

V-4型消声器
V-4 Type Series Muffler



产品代号 Code	螺纹 Screw thread		S mm
	尺寸 Size		
V4-1	M5		8
V4-2	1/8"		13
V4-3	1/4"		16
V4-4	3/8"		19
V4-5	1/2"		24

V-B型消声器
V-B Type Series Muffler



产品代号 Code	螺纹 Screw thread		S mm
	尺寸 Size		
VB-6	1/8"		6
VB-8	1/4"		6.5
VB-10	3/8"		7
VB-15	1/2"		8
VB-20	3/4"		10
VB-25	1"		11

螺纹代号: BSPP BSPT NPT

PDK型消声排气节流阀
PDK Type Exhaust Muffling Throttle Valve



产品代号 Code	螺纹 Screw thread		S mm
	尺寸 Size		
PDK-6	1/8"		13
PDK-8	1/4"		14
PDK-10	3/8"		17
PDK-15	1/2"		22
PDK-20	3/4"		27
PDK-25	1"		34

SVT型消声排气节流阀
Exhaust Muffler Throttle Valve Series



产品代号 Code	螺纹 Screw thread		S mm
	尺寸 Size		
SVT-4	1/8"		14
SVT-6	1/4"		17
SVT-8	3/8"		22
SVT-12.5	1/2"		27

SS-PDK型不锈钢消声排气节流阀
SS-PDK Type Exhaust Muffling Throttle Valve



产品代号 Code	螺纹 Screw thread		S mm
	尺寸 Size		
SS-PDK-6	1/8"		13
SS-PDK-8	1/4"		14
SS-PDK-10	3/8"		17
SS-PDK-15	1/2"		22
SS-PDK-20	3/4"		27
SS-PDK-25	1"		34

PTV型塑料排气节流阀
PTV Plastic Exhaust Muffling Throttle Valve



产品代号 Code	螺纹 Screw thread		Φ mm
	尺寸 Size		
PVT-6	1/8"		10
PVT-8	1/4"		14
PVT-10	3/8"		17
PVT-15	1/2"		24
PVT-20	3/4"		30
PVT-25	1"		36

PF型塑料排气节流阀
PF Plastic Exhaust Muffling Throttle Valve



产品代号 Code	螺纹 Screw thread		Φ mm
	尺寸 Size		
PF-6	1/8"		13
PF-8	1/4"		15
PF-10	3/8"		20

SB型消声器
SB Type Series Muffler



产品代号 Code	螺纹 Screw thread		S mm
	尺寸 Size		
SB-6	1/8"		11
SB-8	1/4"		14
SB-10	3/8"		17
SB-15	1/2"		22
SB-20	3/4"		27
SB-25	1"		33
SB-32	1 1/4"		43
SB-40	1 1/2"		51
SB-50	2"		60

螺纹代号: BSPP BSPT NPT

SDV型铜接头消声器
SDV Type Series Muffler



产品代号 Code	螺纹 Screw thread	S mm
	尺寸 Size	
SDV-6	1/8"	13
SDV-8	1/4"	16
SDV-10	3/8"	19
SDV-15	1/2"	24
SDV-20	3/4"	30
SDV-25	1"	36

SD型调速消声器
SD Type Timing Muffler



产品代号 Code	螺纹 Screw thread	S mm
	尺寸 Size	
SD-6	1/8"	12
SD-8	1/4"	15
SD-10	3/8"	19
SD-15	1/2"	22
SD-20	3/4"	27
SD-25	1"	34

DS型消声排气节流阀
DS Type Exhaust Muffling Throttle Valve



产品代号 Code	螺纹 Screw thread	S mm
	尺寸 Size	
DS-6	1/8"	16
DS-8	1/4"	16

A型消声排气节流阀
A Type Exhaust Muffling Throttle Valve



产品代号 Code	螺纹 Screw thread	S mm
	尺寸 Size	
A-6	1/8"	14
A-8	1/4"	16
A-10	3/8"	17
A-15	1/2"	24
A-20	3/4"	27
A-25	1"	34

B型消声排气节流阀
B Type Exhaust Muffling Throttle Valve



产品代号 Code	螺纹 Screw thread	S mm
	尺寸 Size	
B-6	1/8"	12
B-8	1/4"	14
B-10	3/8"	17
B-15	1/2"	24
B-20	3/4"	27
B-25	1"	34

C型消声排气节流阀
C Type Exhaust Muffling Throttle Valve



产品代号 Code	螺纹 Screw thread	S mm
	尺寸 Size	
C-6	1/8"	13
C-8	1/4"	14
C-10	3/8"	17
C-15	1/2"	22
C-20	3/4"	27
C-25	1"	34

螺纹代号: BSPP BSPT NPT

SC型消声器钢镀铜接头
SC Type Series Muffler Steel Copper Plating Feet



产品代号 Code	螺纹 Screw thread	Φ mm
	尺寸 Size	
SC-M5	M5	8.5
SC-6	1/8"	12
SC-8	1/4"	15
SC-10	3/8"	19
SC-15	1/2"	23
SC-20	3/4"	30
SC-25	1"	35

SET型消声器钢镀铜接头
SET Type Series Muffler Steel Copper Plating Feet



产品代号 Code	螺纹 Screw thread	S mm
	尺寸 Size	
SET-6	1/8"	8
SET-8	1/4"	10
SET-10	3/8"	13
SET-15	1/2"	15
SET-20	3/4"	19
SET-25	1"	24

CB型紫铜接头消声器
CB Type Series Muffler Pure Copper Feet



产品代号 Code	螺纹 Screw thread	Φ mm
	尺寸 Size	
CB-M5	M5	8
CB-06	1/8"	11
CB-6	1/8"	13

SEB型消声器钢镀铜接头
SEB Type Series Muffler Steel Copper Plating Feet



产品代号 Code	螺纹 Screw thread	Φ mm
	尺寸 Size	
SEB-M5	M5	7
SEB-6	1/8"	12
SEB-8	1/4"	15
SEB-10	3/8"	19
SEB-15	1/2"	23
SEB-20	3/4"	30
SEB-25	1"	36

SCQ型消声器钢镀铜接头
SCQ Type Series Muffler Steel Copper Plating Feet



产品代号 Code	螺纹 Screw thread	S mm
	尺寸 Size	
SCQ-6	1/8"	7
SCQ-8	1/4"	8
SCQ-10	3/8"	10
SCQ-15	1/2"	14
SCQ-20	3/4"	17
SCQ-25	1"	21

SCM型紫铜接头消声器
SCM Type Series Muffler Pure Copper Feet



产品代号 Code	螺纹 Screw thread	S mm
	尺寸 Size	
SCM-5M	M5	7
SCM-6	1/8"	11
SCM-8	1/4"	15

螺纹代号: BSPP BSPT NPT

SEB-B-2型消声器钢接头镀彩锌
Riveted And Plating The Color Zine Coupler



产品代号 Code	螺纹 Screw thread	S mm
	尺寸 Size	
SEB-B-2-6	1/8"	11
SEB-B-2-8	1/4"	14
SEB-B-2-10	3/8"	17
SEB-B-2-15	1/2"	22
SEB-B-2-20	3/4"	27
SEB-B-2-25	1"	33

V-1型消声器钢接头镀彩锌
V-1 Silencer With Plating The Color Zine Coupler



产品代号 Code	螺纹 Screw thread	S mm
	尺寸 Size	
V1-6	1/8"	11
V1-8	1/4"	14
V1-10	3/8"	17
V1-15	1/2"	22
V1-20	3/4"	27
V1-25	1"	33

SSM型不锈钢消声器
SSM Type Series Muffler



产品代号 Code	螺纹 Screw thread	S mm
	尺寸 Size	
SSM-M5	M5	8
SSM-6	1/8"	12
SSM-8	1/4"	15
SSM-10	3/8"	19
SSM-15	1/2"	23
SSM-20	3/4"	30
SSM-25	1"	36

SEB-B-1型消声器整体镀镍
Piveted And Plated The Nickel Wholly



产品代号 Code	螺纹 Screw thread	S mm
	尺寸 Size	
SEB-B-1-6	1/8"	12
SEB-B-1-8	1/4"	15
SEB-B-1-10	3/8"	19
SEB-B-1-15	1/2"	23
SEB-B-1-20	3/4"	30
SEB-B-1-25	1"	35

SS-V型不锈钢消声器
SS-V Type Series Muffler



产品代号 Code	螺纹 Screw thread	S mm
	尺寸 Size	
SS-V-M5	M5	8
SS-V-6	1/8"	12
SS-V-8	1/4"	15
SS-V-10	3/8"	19
SS-V-15	1/2"	23
SS-V-20	3/4"	30
SS-V-25	1"	36

SSDV型不锈钢接头消声器
SSDV Type Series Stainless Steel Muffler



产品代号 Code	螺纹 Screw thread	S mm
	尺寸 Size	
SSDV-6	1/8"	13
SSDV-8	1/4"	16
SSDV-10	3/8"	19
SSDV-15	1/2"	24
SSDV-20	3/4"	30
SSDV-25	1"	36

螺纹代号: BSPP BSPT NPT

LM铝合金消声器
LM Type Series Aluminous Muffler

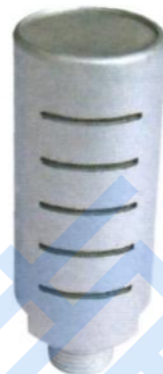

产品代号 Code	螺纹 Screw thread	Φ mm
	尺寸 Size	
LM-1	1/8"	20.5
LM-2	1/4"	20.5
LM-3	3/8"	32
LM-4	1/2"	32
LM-6	3/4"	51
LM-8	1"	51

AM铝合金消声器
AM Type Series Aluminous Muffler



产品代号 Code	螺纹 Screw thread	S mm
	尺寸 Size	
AM-6	1/8"	16
AM-8	1/4"	19
AM-10	3/8"	22
AM-15	1/2"	29
AM-20	3/4"	38

XY铝合金消声器
XY Type Series Aluminous Muffler



产品代号 Code	螺纹 Screw thread	L mm
	尺寸 Size	
XY-05	1/2"	159
XY-07	3/4"	180
XY-10	1"	218
XY-12	1 1/4"	218
XY-15	1 1/2"	340
XY-20	2"	470

PSU铝塑料消声器
PSU Type Plastic Muffler



产品代号 Code	螺纹 Screw thread	Φ mm
	尺寸 Size	
PSU-M5	M5	7
PSU-6	1/8"	13
PSU-8	1/4"	17
PSU-10	3/8"	25
PSU-15	1/2"	25
PSU-20	3/4"	38
PSU-25	1"	48

PSE铝塑料消声器
PSE Type Plastic Muffler



产品代号 Code	螺纹 Screw thread	Φ mm
	尺寸 Size	
PSE-M5	M5	7
PSE-6	1/8"	13
PSE-8	1/4"	17
PSE-10	3/8"	25
PSE-15	1/2"	25
PSE-20	3/4"	37
PSE-25	1"	48

SU铝塑料消声器
SU Type Plastic Muffler



产品代号 Code	螺纹 Screw thread	Φ mm
	尺寸 Size	
SU-6	1/8"	16
SU-8	1/4"	20
SU-10	3/8"	24
SU-15	1/2"	24
SU-20	3/4"	48
SU-25	1"	48



通用范围/General use range

本系列产品是单向型控制元件，可将系统中工作过的压缩空气快速排放。一般配置在汽缸和换向阀之间，使汽缸内的气体不通过换向阀快速排出。用于使气动元件或装置快速排气的场合。

General application range This product is one-way type direction control component, it could exhaust fast the compressed air produced from work system. It generally is installed between reversing-valve and air cylinder so as to make the air inside cylinder not exhaust fast through reversing valve. It is applied to the certain place driving pneumatic component or appliance exhaust fast.

JIS图形符号/JIS Figure symbol

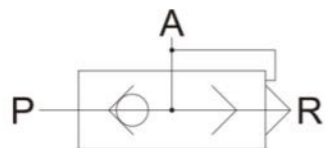

型号说明 Model expressing methods

KS

快排阀

06

接管口径

- 06: G1/8
- 08: G1/4
- 10: G3/8
- 15: G1/2
- 20: G3/4
- 25: G1

标准规格 Standard specification

项目 Model	接管螺纹 Adapter's thread	口径 Latus rectum	开启压力 Opened pressure	使用流体 Use fluid	压力范围 Pressure scope	使用温度 Use the temperature
KS-06	G1/8	6	≤0.03S	压缩空气 Compressed air	0.05~1.2 Mpa	-5~60℃
KS-08	G1/4	8				
KS-10	G3/8	10	≤0.04S			
KS-15	G1/2	15				
KS-20	G3/4	20	≤0.05S			
KS-25	G1	25				

标准规格 Standard specification

型号Model	A	B	C	D	E	F	G	H
KS-06	40	32	27	11	30	Φ4.3	G1/8	22
KS-08	55	40	32	16	39	Φ5.5	G1/4	26
KS-10	55	40	32	16	39	Φ5.5	G3/8	26
KS-15	99	60	50	20	60	Φ8.5	G1/2	40
KS-20	99	60	50	20	60	Φ8.5	G3/4	40
KS-25	113	75	63	26	80	Φ8.5	G1	50



通用范围/General use range

单向型方向控制元件。常配置于汽缸和换向阀之间，使汽缸内的气体不再过控制阀而由此阀直接排出，适用于要求汽缸快速运动场合。

接管口径: G1/8-G1" 使用压力: 0.05~1.0Mpa 适用温度: -5~60℃

General application range one-way type direction control component, it always is installed between reversing valve and air cylinder so as to make the air inside cylinder discharge directly through this valve not control valve, it is applied to the certain place requiring cylinder's fast operation.

Adapter diameter: G1/8-G1" Use pressure: 0.05~1.0Mpa Use temperature: -5~60℃

符号



订购码

KP

L

20

快速排气阀

螺纹连接

公称口径

- 3: G1/8"
- 8: G1/4"
- 10: G3/8"
- 15: G1/2"
- 20: G3/4"
- 25: G1"

外部规格

型号	ZG	L1	L2	L3	L4	D
KP-L3	G1/8"	11	10	39	39	Φ25
KP-L8	G1/4"	18	15	49	48	Φ32
KP-L10	G3/8"	20	18	69	67	Φ49
KP-L15	G1/2"	20	18	69	67	Φ49
KP-L20	G3/4"	23	23	112	100	Φ74
KP-L25	G1"	25	25	112	100	Φ74

单位: mm

规格

公称口径 (mm)	3	8	10	15	20	25
接管口径	G1/8"	G1/4"	G3/8"	G1/2"	G3/4"	G1"
工作介质	干燥, 洁净含有油雾的压缩空气					
工作压力范围 (Mpa)	0.12~0.8					
使用温度范围 (℃)	-20~+50(但在不结冻的条件下)					
有效截面积(mm²)	P→A	4	20	40	60	110
	A→O	8	40	60	110	300
换向时间(s)	P→A	≤0.04		≤0.05		≤0.06
	A→O	≤0.03		≤0.04		≤0.05



型号说明

HSV 08 SS

规格代号 螺接管口径 安装形式

HSV:手滑阀 06:PT1/8 空白:标准型
08:PT1/4 SS:双外牙型
10:PT3/8 FF:双内牙型
15:PT1/2 SF:外内牙型

符号

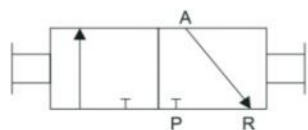

规格

项目/型号	HSV06	HSV08	HSV10	HSV15
工作介质	空气 (经40nm滤网过滤)			
接管口径代号	06	08	10	15
接管口径	PT1/8	PT1/4	PT3/8	PT1/2
有效截面积 (CV)	23mm ² (1.28)	40mm ² (2.2)	62mm ² (3.5)	140mm ² (7.8)
使用压力	0~1.0Mpa(0~142Psi)			
保证耐压力	1.5Mpa(213Psi)			
工作温度	-5~60°C(28~140F)			

FJ10 系列浮动接头

FDSCM 系列浮动接头



订货型号

FJ10 - 08
系列号 螺紋接口

FDSCM - M10x1.25
系列号 螺紋接口

外型尺寸

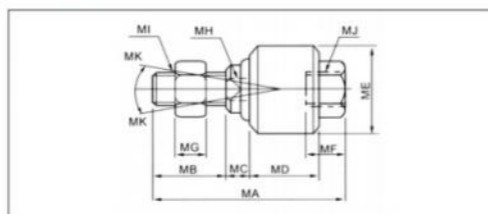

型号	FJ1004	FJ1005	FJ1006	FJ1008	FJ1010	FJ1012	FJ1014	FJ1016	FJ1018	FJ1020	FJ1022	FJ1026	FJ1027	FJ1030	FJ1036
螺紋接口	M4x0.7	M5x0.8	M6x1	M8x1.25	M10x1.25	M12x1.25	M14x1.5	M16x1.5	M18x1.5	M20x1.5	M22x1.5	M26x1.5	M27x2	M30x1.5	M36x2



型号	产品规格 H×T
BCK-22HH	5/16"×5/16"
BCK-33HH	3/8"×3/8"



型号	产品规格 H×T
BCK-22HF	5/16"×1/4"
BCK-23HF	5/16"×3/8"
BCK-33HF	3/8"×3/8"
BCK-43HF	1/2"×3/8"

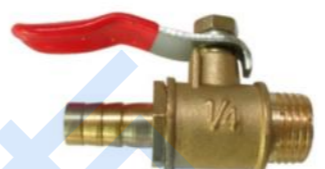

型号	产品规格 H×T
BCK-22HM	5/16"×1/4"
BCK-23HM	5/16"×3/8"
BCK-24HM	5/16"×3/8" T
BCK-32HM	3/8"×1/4"
BCK-33HM	3/8"×3/8"
BCK-34HM	3/8"×1/2"



型号	产品规格 H×T
BCK-11MM	1/8"×1/8"
BCK-22MM	1/4"×1/4"
BCK-33MM	3/8"×3/8"
BCK-44MM	1/2"×1/2"



型号	产品规格 H×T
BCK-11FM	1/8"×1/8"
BCK-22FM	1/4"×1/4"
BCK-33FM	3/8"×3/8"



型号	产品规格 H×T
BCK-11FF	1/8"×1/8"
BCK-22FF	1/4"×1/4"
BCK-33FF	3/8"×3/8"



产品编号 Item No.	产品规格 Measurement	牌价 Iprice
BCK-22BM	1/4"CB×1/4" T	125
BCK-22BM-1	5/16"CB×1/4" T	125
BCK-32BM	3/8"CB×1/4" T	135
BCK-33BM	3/8"CB×3/8" T	135



产品编号 Item No.	产品规格 Measurement	牌价 Iprice
BVF-020	1/4"	130
BVF-030	3/8"	130
BVF-040	1/2"	130
BVF-060	3/4"	170
BVF-080	1"	260
BVF-120	1 1/4"	380
BVF-150	1 1/2"	580
BVF-200	2"	880
BVF-250	2 1/2"	
BVF-300	3"	
BVF-400	4"	



产品编号 Item No.	产品规格 Measurement
SVF-020	1/4"
SVF-030	3/8"
SVF-040	1/2"
SVF-060	3/4"
SVF-080	1"
SVF-120	1 1/4"
SVF-150	1 1/2"
SVF-200	2"

安全阀



PU TUBE PU管



特点:

PU管是由polyurethane加工而成的, 具有良好弹性体, 适用于弯曲大的场所, 耐气候、耐摩擦抗振动、耐曲折。适合各种接头, 便于布管作业, 使用方便灵活。

PU hose processed by Polyurethane, with very good elasticity, PU hose is applicable to occasions of big bending, temperature-resistance, anti-rubbing, anti-vibration and twist-resistance. PU hose suitable for various of fittings, easy for piping-work and flexible in application.

订购编号: Order Model

PU 8 × 5.5/100M-BU

系列 Sieres 规格 Size 长度 Length 颜色 Colour

气管颜色: Colours

C 透明/Transparent **B** 黑/Black **BU** 蓝/Blue **R** 红/Red **Y** 黄/Yellow

型号	外径	内经	壁厚	爆破压力	工作压力	弯曲	公斤/卷	卷/箱	材积
PU4x2.5/200M	4	2.5	0.75	30	10	12	1.8	10	0.09
PU5x3/200M	5	3	1	30	10	15	2.4	6	0.09
PU6x4/200M	6	4	1	30	10	15	3.8	6	0.09
PU8x5/100M	8	5	1.5	30	10	20	3.8	6	0.09
PU8x5.5/100M	8	5.5	1.25	24	8	25	3.2	6	0.09
PU8x6/100M*	8	6	1	21	7	30	2.7	6	0.09
PU10x6.5/100M	10	6.5	1.75	30	10	30	5.6	4	0.09
PU10x7/100M*	10	7	1.5	24	8	32	4.9	4	0.09
PU10x8/100M*	10	8	1	21	7	35	3.5	4	0.09
PU12x8/100M	12	8	2	30	10	35	7.6	4	0.12
PU12x9/100M	12	9	1.5	21	7	40	6.2	4	0.12
PU16x12/100M	16	12	2	24	8	40	11	3	0.15
PU16x13/100M	16	13	1.5	18	6	50	8.5	3	0.15
PU1/4-200M	6.3	4.5	0.9	30	10	15	3.8	6	0.09
PU5/16-100M	8	5	1.5	30	10	20	3.8	6	0.09
PU3/8-100M	9.5	6.5	1.5	21	7	30	4.7	4	0.09
PU1/2-100M	12.6	9.6	1.5	21	7	40	7.0	4	0.12

颜色: 欢迎订做特殊颜色和规格。
Colour: special size and colours can be available according to order.

PA6PA.12尼龙管 NYLON TUBE



特点:

1. 尼龙管分为尼龙6和尼龙12既是 (PA6、PA12), 采用日本进口原材料, 具有良好的理化性能和机械性能: 是替代金属最好的一种管。
2. 耐曲折, 耐磨损, 耐压力, 可以在有沙石、铁屑等恶劣条件下使用; 耐候性好, 可在-40-100℃的环境下工作。表面光滑, 减小阻力, 能防止生锈和结垢淤积; 因此尼龙管可用做输送压缩空气、水、燃料油、化学溶剂、液态食品等。柔软, 易弯曲, 便于安装, 加工简单; 当需要一定形状时, 可以像金属管一样制成各种形状, 不需要复杂的设备和工装。

1. PA Nylon divided as Nylon 6 and Nylon 12(PA6, PA12) using raw material from Japan, as due to the excellent Physical and Chemical Properties as well as the mechanical performance it is the best tube to replace metal tube.
2. Twist-resistance, Anti-rubbing, Pressure-resistance PA tube can be used under the severe condition of sand-gravel, iron-chipping etc it can be working at the temperature 40-100℃ with good temperature-resistance. As due to PA Tubing with smooth surface which can keep from the rusty and dirt PA tube used widely to transport compressed air, water, fuel oil, chemical solvent, liquid food etc. PA tube can be perform as metal tube without complicate Equipment and tooling when you definite shape.

订购编号: Order Model

PU 8 × 5.5/100M-BU

系列 Sieres 规格 Size 长度 Length 颜色 Colour

气管颜色: Colours

C 透明/Transparent **B** 黑/Black **R** 红/Red **Y** 黄/Yellow

型号	外径	内经	壁厚	爆破压力	工作压力	公斤/卷	卷/箱	材积
PA4 x 2.5/200M	4	2.5	0.75	60	20	1.7	10	0.12
PA6x4/200M	6	4	1	60	20	3.5	10	0.18
PA8x6/100M	8	6	1	60	20	2.4	10	0.18
PA10x7.5/100M	10	7.5	1.25	60	20	3.8	6	0.15
PA10x8/100M	10	10	1	45	15	3.1	6	0.15
PA12x9/100M	12	12	1.5	60	20	5.5	6	0.24
PA12x10/100M	12	12	1	45	15	3.8	6	0.24
PA16x12/100M	16	16	2	60	20	9.7	3	0.16
PA1/4-200M	6.3	4.6	0.85	60	20	3.2	10	0.18
PA5/16-100M	8	6	1	60	20	2.4	10	0.18
PA3/8-100M	9.5	7	1.25	60	20	3.6	6	0.15
PA1/2-100M	12.5	9.5	1.6	60	20	6	6	0.24

PETUBE PE管



特点:

该管专用于耐腐蚀化学品的输送各种溶剂。主要用于涂料生产、印刷输送油墨、溶剂，储存、运输等，并有极好的弯曲性能。

PE tube Specially applicable to transport Various solvents of erosion chemical Mainly be used to transport the paint, printing ink, solvents etc with excellent bending performance.

订购编号:
Order Model

PE 8 × 6/100M-C

系列 Sieres | 规格 Size | 长度 Length | 颜色 Colour
 C 透明/Transparent | B 黑/Black | R 红/Red | Y 黄/Yellow

气管颜色:
Colours

型号	外径	内经	壁厚	爆破压力	工作压力	公斤/卷	卷/箱	材积
PA4 x 2.5/200M	4	2.5	0.75	30	10	1.5	10	0.12
PA6x 4/200M	6	4	1	30	10	3	10	0.18
PA8x6/100M	8	6	1	21	7	2.1	10	0.18
PA10x7.5/100M	10	7.5	1.25	30	10	3.3	6	0.15
PA10x8/100M	10	10	1	21	7	2.7	6	0.15
PA12x9/100M	12	12	1.5	30	10	4.8	6	0.24
PA12x10/100M	12	12	1	21	7	3.3	6	0.24
PA16x12/100M	16	16	2	30	10	8.5	3	0.16
PA1/4-200M	6.3	4.6	0.85	30	10	2.8	10	0.18
PA5/16-100M	8	6	1	210	7	2.1	10	0.18
PA3/8-100M	9.5	7	1.25	30	10	3.1	6	0.15
PA1/2-100M	12.5	9.5	1.6	30	10	5.2	6	0.24

PU 螺旋管 /PU COIL TUBE



特点:

轻便、柔韧、耐久。伸缩自由，使用简单。

Light, flexible and durable. Free extension and easy use.

代码/Code	EUC6-2	EUC6-4	EUC6-6	EUC6-8	EUC6-10	EUC6-15	EUC6-20	EUC8-2	EUC8-4	EUC8-6	EUC8-8	EUC8-10	EUC8-15	EUC8-20
外径(mm) External diameter	6	6	6	6	6	6	6	8	8	8	8	8	8	8
长度(m) Length	2	4	6	8	10	15	20	2	4	6	8	10	15	20

代码/Code	EUC6-2	EUC6-4	EUC6-6	EUC6-8	EUC6-10	EUC6-15	EUC6-20	EUC8-2	EUC8-4	EUC8-6	EUC8-8	EUC8-10	EUC8-15	EUC8-20
外径(mm) External diameter	10	10	10	10	10	10	10	12	12	12	12	12	12	12
长度(m) Length	2	4	6	8	10	15	20	2	4	6	8	10	15	20

PU 螺旋管 /PU COIL TUBE

特点:

- 1、采用日本进口刀片。
- 2、能够安全、快速、准确、平整地切断气管。

1. Adoption of Japan imported blade.
2. Safety, fast, accurately and precision cuts of tubes.

